

MANUAL

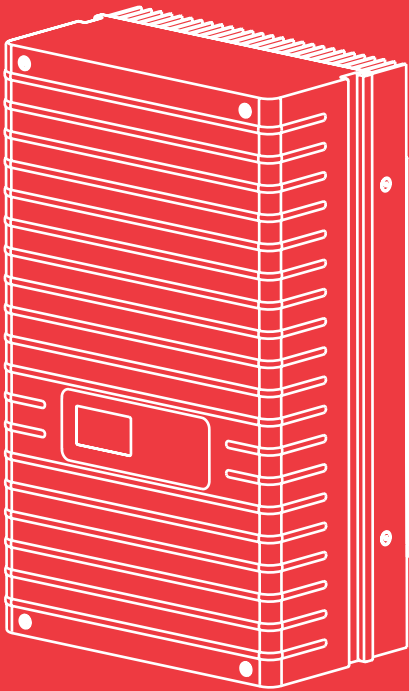

User Manual Sunways Solar Inverter

AT 2700, AT 3000, AT 3600,
AT 4500, AT 5000

english

EN

sunways
Photovoltaic Technology

Imprint

All rights reserved.

© Copyright by:

Sunways AG

Photovoltaic Technology

Macairestraße 3 - 5

78467 Konstanz

Germany

This user manual may only be reprinted or copied in whole or in part with the express, written approval of Sunways AG. Any type of reproduction, distribution or storage on data carriers in any form and of any kind not authorised by Sunways AG represents a violation of the applicable copyright laws and will be prosecuted. We reserve the right to make technical changes which serve to improve the device, or which increase the safety standard – even without separate prior notice.

Publisher responsible for the content: Sunways AG

This user manual contains products and product names which are registered trademarks. The mention of products and product names is used only for information purposes and does not represent product misuse. The passage referring to these products in this user manual does not represent original documentation of the respective product.

Introduction

Thank you for deciding in favour of a Sunways Solar Inverter of the AT Series!

In doing so you have purchased an innovative, high-quality product with unique equipment features and a high, constant efficiency. This Solar Inverter is equipped with HERIC® topology and innovative FP switching, and therefore enables operation on a large number of silicon and thin-film modules – as accustomed from Sunways – without the use of a transformer.

This user manual contains explanations on using the Sunways Solar Inverter. You will learn to recognise the many possibilities of the Solar Inverter. Information is provided on safety, installation, commissioning, operation and system monitoring.

Please observe the safety precautions exactly to ensure increased safety at the operating site of the Solar Inverter.

Content

1	Product description	7
	1.1 Proper use	7
	1.2 Function description	7
	1.3 Integration in solar system	8
	Design of solar generator	8
	Standard components of a solar system	9
	1.4 Assembly description	9
	1.5 Delivery scope	10
2	Safety precautions	11
	2.1 General safety precautions	11
	2.2 Explanation of symbols and warnings	12
	Warnings and symbols used in this user manual	12
	Symbols used in this user manual	12
	Warnings and symbols on device	12
	2.3 Basic safety measures	13
	2.4 Safety concept	13
3	Installation	14
	3.1 Mechanical installation	14
	Requirements for installation location	14
	Installation	15
	3.2 Electrical installation	16
	Solar generator connection	16
	Grid connection	20
	3.3 Installing communication	22
	Interface overview	22
	Networking Solar Inverters via CAN bus	23
	Networking Solar Inverters via RS485 interface	25
	S0 interface	26
	Connection of temperature and irradiation sensor	26
	Connecting alarm relay	27

4	Commissioning	28
4.1	Connecting and disconnecting Solar Inverter	28
	Connecting	28
	Switching off	28
4.2	Commissioning	29
	Commissioning single device	29
	Commissioning several networked devices	30
	Later commissioning	34
5	Operation	35
5.1	Operating elements	35
	Operating field	35
	LCD display	35
	Operating LED	35
	Standard screen (single device)	36
	Standard screen (system)	36
5.2	Access rights	37
	Customer area	37
	Installer area	37
5.3	Menu structure	38
5.4	Overview of screen displays	39
5.5	Malfunction displays	46
	Solar generator fault	46
	AC network fault	47
	Inverter fault	49
	Interface/communication fault	51
	Service fault	54
6	System monitoring	55
6.1	General information	55
6.2	Integrated data logger	55
6.3	Direct Ethernet connection	56
6.4	Network settings on Solar Inverter	57
6.5	Network settings on the PC	58
6.6	Connection via an existing Ethernet network	60
6.7	Access via DSL router	61

Content

6.8	Connection via the Sunways Modem	61
6.9	Dial-up connection from a PC to the Solar Inverter	62
6.10	Sunways Browser	65
	General information	65
	Access protection	65
	Overview – Menu	66
	Language selection	66
	Setting the date/time	66
	Software update	67
6.11	Internet dial-up via modem	67
	Modem settings	67
	E-mail settings	68
6.12	Active alerting	69
	General information	69
	Alerting settings	69
6.13	Sunways Portal connection	70
	General information	70
	Setup	70
7	Appendix	72
7.1	Technical data	72
7.2	Drilling template for wall bracket	74
7.3	General liability disclaimer	75

1 Product description

1.1 Proper use

The Sunways AT Solar Inverter is the link between your solar generator and the public power grid. The energy from the connected solar generator is converted to grid-conformant AC current and fed into the grid.

Thanks to the HERIC® topology with FP switching, the AT Solar Inverter has a voltage curve which corresponds to that of a transformer device with an earthed negative terminal, and is generally also recognized for operation on thin-film modules.

Solar modules which require earthing of the positive terminal cannot be operated with the AT Solar Inverter. If in doubt, always ask your module manufacturer about a release!

1.2 Function description

Conversion from direct into alternating current

The AT Solar Inverter converts the direct current produced by the solar generator into alternating current. The alternating current is then fed into the public power grid.

Operating and display elements

Various interfaces are available for system configuration and monitoring:

- Operating field (LCD display and keyboard) for displaying operating and status values or for inputting system parameters
- Operating LED
- Integrated web server for display and configuration via a web browser

Interfaces

- Bus interface for connecting an analogue modem, ISDN modem or GSM/GPRS modem
- Ethernet interface for connecting a PC or for integration in existing networks
- CAN bus interface for interconnecting several Solar Inverters

- 50 pulse output for controlling large displays
- Alarm relay for realising simple monitoring locally
- Interface for connecting an irradiation and temperature sensor

Data logging

The AT Solar Inverter is equipped with internal data logging for recording and saving system data:

- 5-minute mean values of voltages, currents, output, temperature and irradiation (if sensor is installed)
- 5-minute, daily, monthly and annual values of energy yield
- Memory for malfunction messages

Grid monitoring

The AT Solar Inverter assumes the task of grid monitoring for the protection of the device and persons. In case of abnormal grid conditions, feeding is immediately interrupted and the Solar Inverter disconnects from the grid by triggering the grid relay.

Design of Solar Inverter

The principle design of the AT Solar Inverters can be recognised from the block diagram. The most important characteristic of the inverter is the earthing of the solar generator, i.e. the negative terminal is directly connected to the neutral conductor on the grid.

The solar generator voltage connected to the inverter input is always positive and is initially adapted by the DC actuator and then converted to alternating current by the high-efficiency HERIC® inverter.

Block diagram

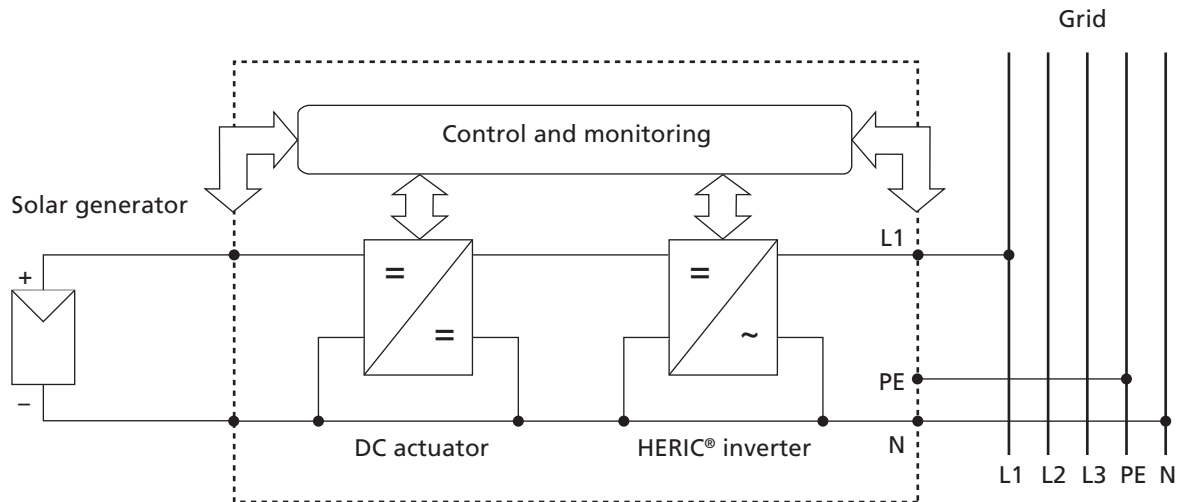

1.3 Integration in solar system

Design of solar generator

The technical data of the selected solar generator must be within the Solar Inverter's specifications (see Technical Data). Incorrect dimensioning can lead to reductions in the yield and to destruction of the device.

The design program Sunways Sundim may be helpful to you. Sunways Sundim is available on the included CD-ROM or at our homepage www.sunways.de.

Be sure to take the following points into account before planning your system:

- Watch the celestial alignment of the modules. A maximum yield is achieved in Central Europe with a module slope of 30° to the vertical and direction of the solar generator field directly to the south.
- The output of the cells decreases as the module temperature increases. Install your solar generator with sufficient ventilation from behind.

- Check your solar generator approx. every three years for soiling. This occurs especially on the lower edge of the modules and forms a veil that cannot be washed off even by heavy rain. Reduced yield can be prevented by cleaning with a wet cloth or a brush.
- Avoid switching off individual modules or solar cells of your system. This can lead to major decreases in yield.

Standard components of a solar system

Depending on the recommendations of your PV planning expert, your PV system consists of the following components:

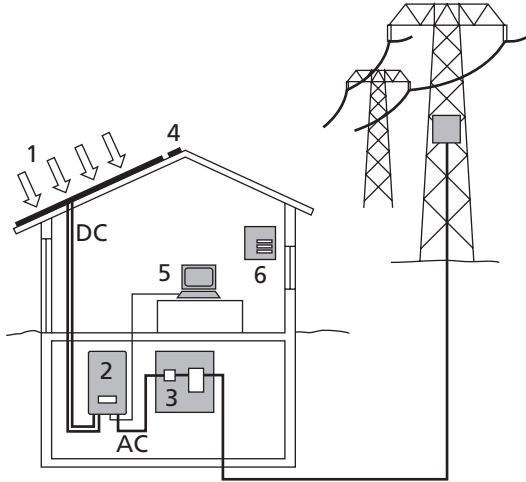

- 1 Solar generator
- 2 Solar Inverter with integrated DC load break switch
- 3 Mains fuse and energy meter

Options

- 4 Irradiation sensor with integrated temperature sensor
- 5 PC for monitoring system
- 6 Large display

1.4 Assembly description

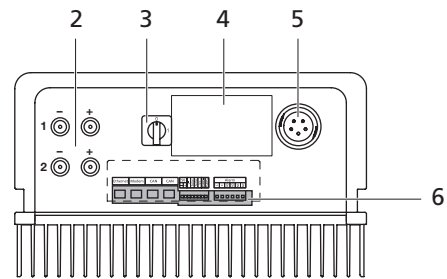
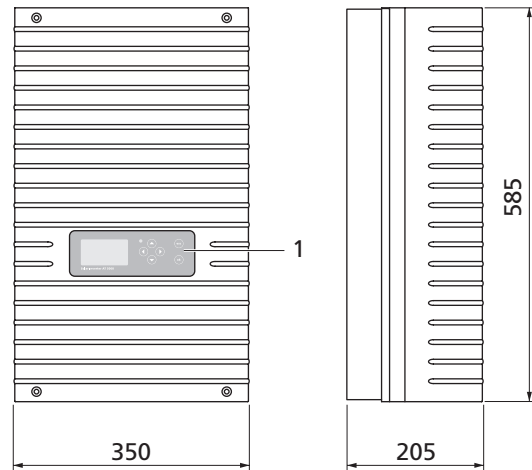

- 1 Operating field with LCD display, operating LED and keyboard
- 2 DC connections
- 3 DC load break switch
- 4 Rating plate
- 5 AC connection
- 6 Communication interfaces

1 Product description

1.5 Delivery scope

The delivery consists of:

- Sunways Solar Inverter of the AT-Series
- Installation frame
- 2 pairs of Tyco Solarlok plug-in connectors
- AC connector
- CAN terminating resistor connector (connected)
- Ethernet cable, 2 m (CAT 5e, 1:1)
- Warranty card
- Setup
- CD-ROM, including: Manual, Sunways Sundim design program, product and service information

Checking delivery

Before shipment our products are checked for proper condition. Despite careful, recyclable packing, transport damage may occur, for which the transport company is generally responsible.

Please check the delivered Solar Inverter thoroughly!

Should you discover damage to the packing or the Solar Inverter, please inform the transport company immediately. Your specialist dealer will be happy to support you if necessary. A possible damage report must always be received by the transport company in writing at the latest seven days after receipt of the goods.

2 Safety precautions

2.1 General safety precautions

Observe information in operating manual!

The condition for the safe handling and malfunction-free operation of the AT Solar Inverter is a knowledge of the basic safety precautions.

This user manual contains the most important information on operating the system safely.

Each person concerned with the installation, commissioning, maintenance and operation of the Solar Inverter must have read and understood the entire user manual, and in particular the chapter entitled Safety Precautions.

In addition, the rules and regulations for accident prevention applicable for the operating site/plant must be observed.

Dangers when handling the AT Solar Inverter

The Solar Inverter has been built in accordance with the latest rules of technology and the recognized safety rules and may only be used

- for its intended use
- when in proper condition with regard to safety.

Improper use may lead to dangers to the life and limb of the user or others, or can adversely affect the system or other property.

In case of malfunctions which can impair safety, the system must be shut down immediately and secured against being switched on again. The malfunction must then be eliminated immediately.

Warranty and liability

The Sunways AG „General Terms and Conditions of Sale and Delivery« always apply. Warranty and liability claims for personal injury or damage to property are excluded, if they were caused by one or more of the following:

- Improper use of the Solar Inverter
- Improper installation, commissioning, operation and maintenance
- Operation of the Solar Inverter with defective and/or non-operational safety and protective equipment
- Failure to observe the information in the user manual regarding installation, commissioning, operation and maintenance
- Unauthorised constructional modifications
- Insufficient monitoring of wearing parts
- Improperly conducted repairs
- Emergencies caused by external influence or force majeure

2 Safety precautions

2.2 Explanation of symbols and warnings

To help you quickly understand this manual and safely use the Solar Inverter, the following warnings and symbols are used.

Warnings and symbols used in this user manual



DANGER

This symbol indicates an immediate danger which will result in death, injury or serious damage if the applicable safety regulations are not followed.



Extreme danger from electric shock!

This symbol indicates an immediate danger from electric shock which will result in death, injury or serious damage if the applicable safety regulations are not followed.



CAUTION

This symbol indicates an immediate danger which can result in damage if the applicable safety regulations are not followed.

Symbols used in this user manual



Information

This symbol indicates important information which contributes to a better understanding of the Solar Inverter.

Warnings and symbols on device

The following warnings on the housing of the Solar Inverter point out dangers. Always observe the warnings exactly.



This symbol indicates that the user manual must be read and understood before putting the device into operation.



IMPORTANT

Hot surface! The housing can heat up during operation.



The device must be disconnected from the mains supply and from the PV generator before opening the housing. The device still carries life-threatening voltage for approx. five minutes internally and at the connection terminals of the PV generator following disconnection from the PV generator. The energy storage capacitors are not completely discharged until after this time. You must wait at least five minutes after disconnecting the device from the mains supply and from the PV generator before opening the device.

Warning!
High leakage current,
earth connection essential before
connecting supply.

WARNING!

High leakage currents. Be sure to make an earthing connection before connecting the power supply circuit (AC system).

2.3 Basic safety measures

Electrical work on the Solar Inverter must be conducted by a qualified electrician while observing the VDE regulations, national and other regulations.

The Solar Inverter may only be opened by persons authorised by Sunways AG to do so.

When circuit breakers are tripped, the fault cause must be determined and eliminated before returning the device to operation.

Check electrical equipment regularly.

Retighten loose connections.

Replace damaged lines/cables immediately.

2.4 Safety concept

The following parameters are monitored and displayed continuously and simultaneously by the inverter controller:

- DC overvoltage
- Overvoltage L1, L2, L3
- Undervoltage L1, L2, L3
- Isolated operation
- Over- / underfrequency L1
- Surge error (brief overvoltage L1)
- DC share in AC current
- AFI residual current
- Overtemperature of heat sink

When a malfunction occurs, feeding is immediately interrupted and the Solar Inverter disconnects from the grid by triggering the grid relay.

The potential-free alarm relay is switched (except for grid undervoltage L1).

In addition, the following protective equipment in accordance with overvoltage category III is provided on the grid and on the solar generator side:

- Grid-side varistors
These protect the power semiconductors in case of high-energy, short-term voltage peaks in the grid and provide for an energy reduction in reactor in case of a grid disconnection.
- Generator-side varistors
Varistors offer protection against atmospheric overvoltages (e.g. caused by remote strikes during thunderstorms).

3 Installation

3.1 Mechanical installation

Requirements for installation location



DANGER

- The Solar Inverter may not be installed in rooms subject to explosion hazards.
- The Solar Inverter may not be exposed to caustic gases!
- No combustible or highly flammable materials may be stored within 3 metres of the Solar Inverter.

Protection against moisture and foreign bodies

The high protection type IP 54 allows installation indoors and in roof-covered areas outdoors, however the Solar Inverter may not be directly exposed to rain.

Mechanical load-bearing capacity

Note during installation that the Solar Inverter weighs 29 kg. The installation surface must be firm and able to carry this weight in the long term.

Thermal interaction

- The installation surface must consist of flame-retardant material (not suitable: surface of wood or plastic; suitable: concrete and masonry), as the frame of the Solar Inverter can heat up to a maximum of 70°C.
- A minimum distance of 300 mm to other devices, cabinets, ceilings, cable ducts, etc. must be maintained above, below and to the sides of the housing. See the figure Requirements for installation location.
- The Solar Inverter must be installed vertically to enable sufficiently free convection.
- Several Solar Inverters may not be mounted over each other to prevent them from heating each other.

- Ensure sufficient heat dissipation when installing the Solar Inverter in a switch cabinet or closed room.
- The ambient temperature may not drop below or exceed -25°C and +40°C respectively. At ambient temperatures above 40°C, the inverter automatically reduces its output.
- The Solar Inverter must not be exposed to direct sunlight, to protect it from unnecessary external warming.

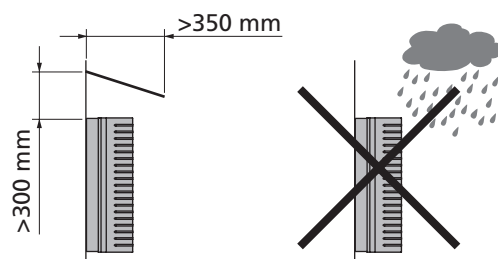
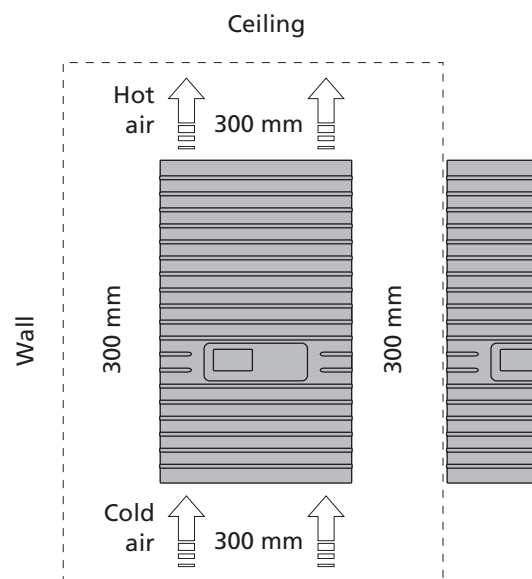

Installation

Proceed as follows to install the Solar Inverter:

1. Hold the wall bracket at the point at which you want to attach the Solar Inverter and mark the mounting holes.

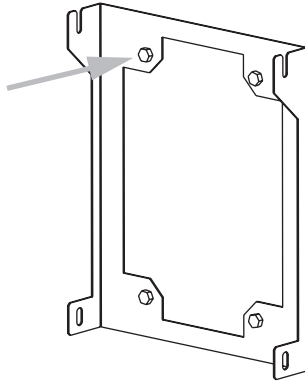

2. Drill the holes with a 10 mm dia. drill bit. A drilling template with exact dimensioning can be found in the appendix.
3. Install the wall bracket with corresponding screws and dowels depending on the surface condition.
4. Unscrew the locking screw of the Solar Inverter at the lower left with an Allen key
5. Hook the Solar Inverter into the cut-outs of the installation frame at the top on both sides.

6. Secure the Solar Inverter by tightening the locking screw.

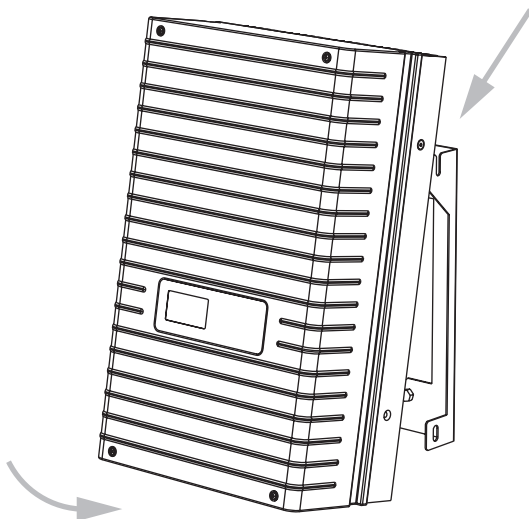
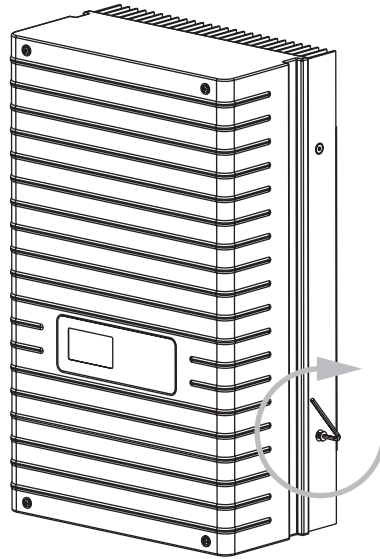

3 Installation

3.2 Electrical installation

Solar generator connection



Extreme danger from electric shock!

- Touching live parts can result in death.
- All electrical work must be conducted by a qualified electrician while observing the VDE regulations, national and other regulations!
- Execute the direct current wiring in accordance with the system dimensioning of your planning expert.
- Prepare all solar generator cables before you carry out the connection of the solar generator to the Solar Inverter.
- Check each solar generator string for proper operation with an open-circuit voltage and short-circuit current measurement.
- Check using the rating plate on the Solar Inverter whether it is approved for the maximum solar generator voltage.
- The positive and negative lines must be kept electrically separate from the earth potential.
- Touchable, live parts of the solar generator (e.g. metal frame, carrying structure, etc.) must be earthed (connection with PE).
- Check the solar generator against short-circuits to earth.
- Before connecting the solar generator to the Solar Inverter, the integrated DC load break switch must be opened quickly (position 0).
- After the PV solar generator is connected to the Solar Inverter and the DC load break switch is switched on, the direct generator voltage is present internally.
- The connectors may not be separated while under load.

- Always separate the grid connection first by switching off the corresponding mains fuse and then the solar generator side by quickly opening the DC load break switch.

Survey

The solar generator can be directly connected to the Solar Inverter with two strings. The connection is made via the shockproof Tyco Solarlok plug-in connection system accessible from outside.

The Solar Inverter has two electrically connected DC inputs, which are arranged in pairs on the underside.



- The solar generator strings must be identically dimensioned and comply with the specifications of the Solar Inverter.
- No external DC load break switch is required. A DC load break switch as required in accordance with DIN VDE 0100-712 is integrated in the Solar Inverter.

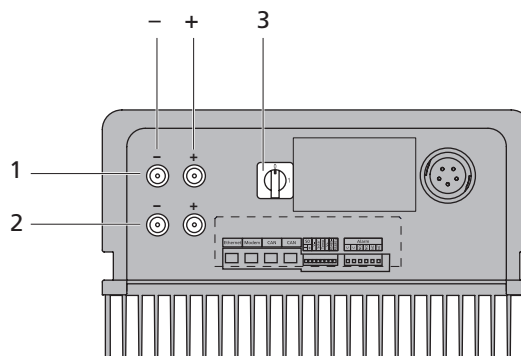

- 1 Connection of solar generator string 1
- 2 Connection of solar generator string 2
- 3 DC load break switch

Tyco Solarlok plug-in connection system

The Solarlok plug-in connection system is used for the simple, reliable connection of individual solar generators up to the Solar Inverter.

Components

The following connectors are used:

- Positively coded connector

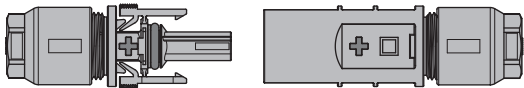

- Negatively coded connector

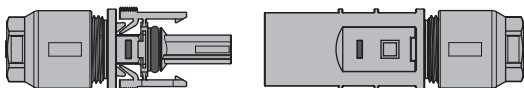

- Neutral connector



The neutral connector can be used to connect both positively and negatively coded sockets.

Installation



Extreme danger from electric shock!

- Touching live parts can result in death.
- All electrical work must be conducted by a qualified electrician while observing the VDE regulations, national and other regulations!
- Tyco Solarlok connectors are only reliable for connection on permanently installed lines.
- Only the Tyco-Solarlok hand crimping pliers may be used to crimp the connectors.

- During preassembly, the connectors must be separated from all other voltage sources.
- The connectors may not be separated while under load. The circuit must be opened at a suitable point for this purpose.
- Provide the lines with corresponding stickers as close as possible to the connectors to prevent confusion.



- Any kind of soiling (dust, moisture, etc.) has a negative effect on the connector system with regard to function over the intended period of use. This particularly applies to the suitability for use of the seals and the crimping of the contacts. Therefore, extreme care must be taken to achieve proper processing during assembly.
- Various circular contacts are used for different conductor cross-sections with the Tyco Solarlok connectors. The correct tool insert must be used in accordance with this cross-section. The included Tyco Solarlok connectors are equipped with circular contacts for a cable cross-section of 4 mm² to 6 mm².
- The seals and clamping baskets used in the preassembled connectors are approved for cable sheath diameters from 4.5 mm to 6.9 mm. Special seals and clamping baskets must be used for cables with a sheath diameter greater than 6.9 mm.
- The Tyco Solarlok hand crimping pliers can be purchased from your sales partner.

3 Installation

The following sequence must be observed during assembly:

1. Stripping the voltage-free line.

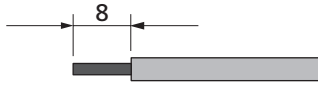

2. Crimping on the circular contact with the Tyco Solarlok hand crimping pliers.



3. Sliding the cable gland onto the line and engaging the contact in the connector housing.

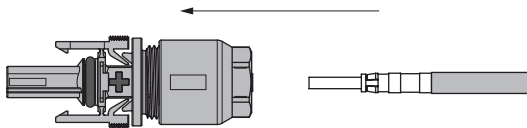

4. Tightening the cable gland with 1.5 Nm.

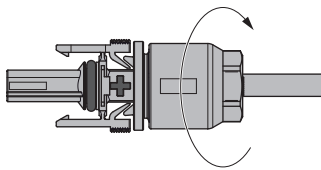

Handling

The positively/negatively coded connectors are marked with polarity symbols and a coloured ring (blue = negative, red = positive). They are equipped with coding ribs for assignment, which ensures that only connectors of the same polarity can be connected to each other.

Connecting socket and plug. The system is only correctly locked if the locking hooks are recessed flush in the mating piece.

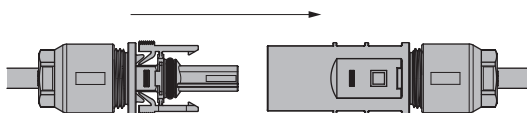

CAUTION

The connectors may not be separated while under load. The circuit must be opened at a suitable point for this purpose.

Release the locking device by pressing on the ribbing of the locking hooks and pulling them apart.

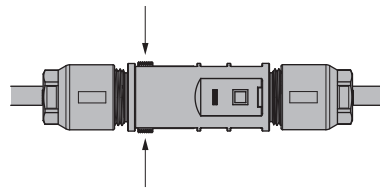

Connection example

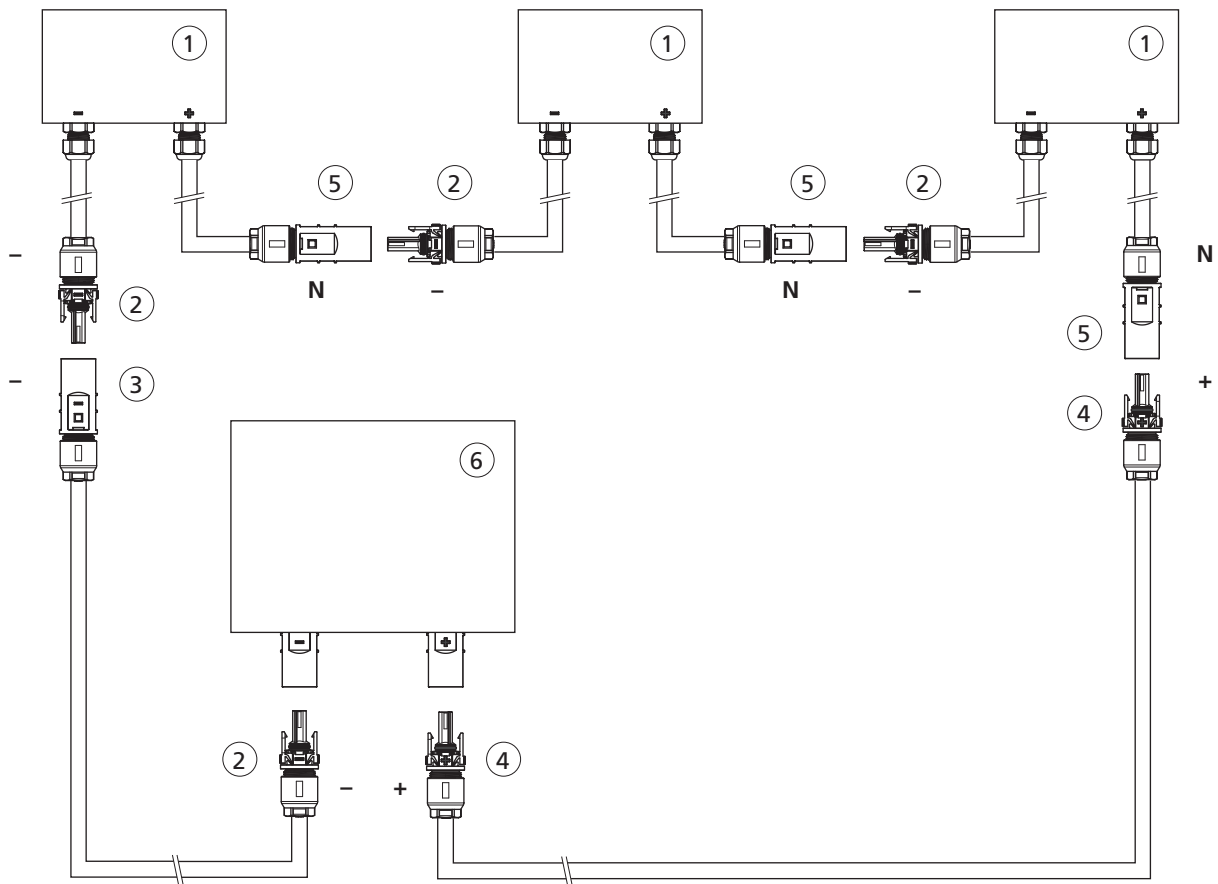

- 1 Solar module box
- 2 Negatively coded socket
- 3 Negatively coded plug
- 4 Positively coded socket
- 5 Neutral connector
- 6 Solar inverter

Grid connection



Extreme danger from electric shock!

- Touching live parts can result in death.
- All electrical work must be conducted by a qualified electrician while observing the VDE regulations, national and other regulations!
- Observe the pin assignment of the AC bayonet connector. An incorrect assignment can result in the device being destroyed.
- No consumers may be connected to the supply line from the Solar Inverter to the mains fuse.
- Always separate the grid connection first by switching off the corresponding mains fuse and then the solar generator side by quickly opening the DC load break switch.



If the voltage on the AC connection exceeds the permissible value due to a long line length or an insufficient cable cross-section, the Solar Inverter will be disconnected from the grid. In power grids with a low output and a high solar generator output, this can lead to individual Solar Inverters being switched off and then on again several times.

Survey

An AC bayonet connector on the underside of the unit is used for the three-wire grid connection (L, N, PE) of the Solar Inverter. The grid connection should always be 1-phase. Feeding is single-phase via AC terminal 2.

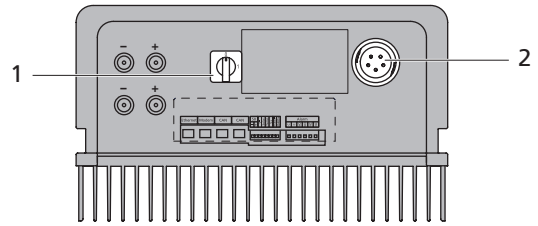

- 1 DC load break switch
- 2 AC connection

A basic distinction is made between two different connection options of the Solar Inverter to the public power grid:

- 3-phase AC grid (e.g. Germany)
- 1-phase AC grid (e.g. Italy, Spain)



CAUTION

- Observe the regional regulations for the grid connection.

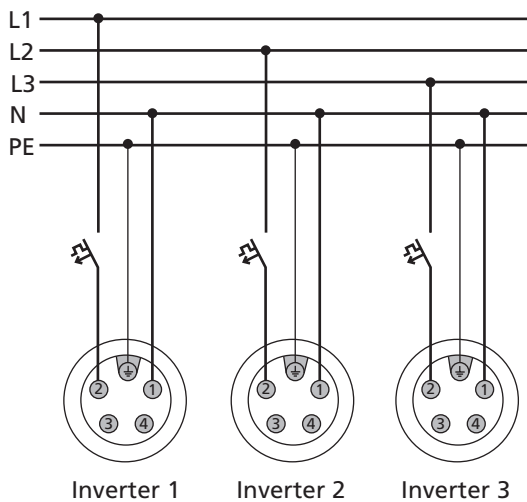
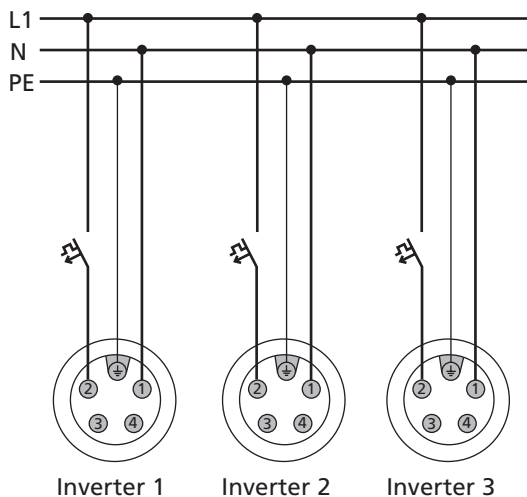

The Solar Inverter always only feeds via AC terminal 2. If several Solar Inverters are operated in parallel in a 3-phase grid, AC terminal 2 of the device must be distributed uniformly among the grid phases L1, L2 and L3 to avoid unequal loading.

3-phase grid connection (3-phase AC connection)**1-phase grid connection (AC connection)**

A corresponding circuit breaker is recommended as a line protection element in the grid feed direction:

AT 2700: 16 A

AT 3000: 16 A

AT 3600: 25 A

AT 4500: 25 A

AT 5000: 32 A

with slow-blow characteristic B



- Depending on the grid operator and the feed point, a three-phase meter or a single-phase meter must be used.
- Some grid operators require the use of a reverse-current-capable meter.

AC bayonet connector

The AC bayonet connector is permissible for cable sheath diameters from 13 mm to 20 mm.

The following sequence must be observed during assembly:

1. Strip the voltage-free line and the cable ends.

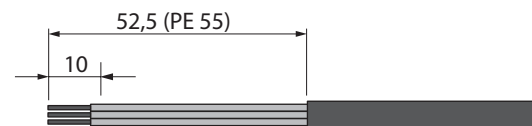

For lines with a cable sheath diameter from 16 to 20 mm, the cable gland must be adapted accordingly. To do this, cut out the inner section of the blue sealing ring.

2. Slid the cable gland and the plug housing onto the line.

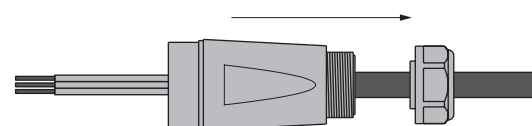

3. Connect the cable ends to the plug terminals in accordance with the pin assignment.
Tightening torque: 0.7 Nm.

**CAUTION**

Incorrect pin assignment may result in destruction of the unit!

Pin assignment for AC bayonet connector



The diagram shows the connections inside the AC connector, as indicated by the cut-out at the PE connection.

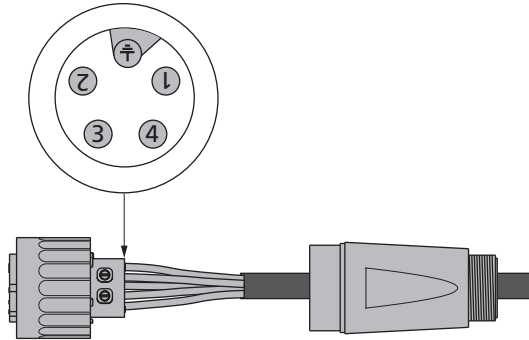

- 1 = N
- 2 = L (feed-in phase)
- 3 = not used
- 4 = not used
- ⊕ = PE (protective earth conductor)

4. Screw plug housing to plug. To do this, press the outer ring of the plug toward the plug housing. Tightening torque: 1-2 Nm.

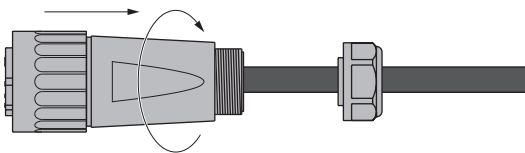

5. Tighten the cable gland.



Make sure the line is provided with a strain relief device. When using cables with a diameter < 16 mm, the line must be relieved just behind the connector.

Tightening torque for cable sheath diameters from 13 to 20 mm = 6 to 8 Nm

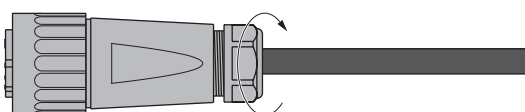

3.3 Installing communication

The interfaces are located behind the weather-proof connection box on the underside of the Solar Inverter.

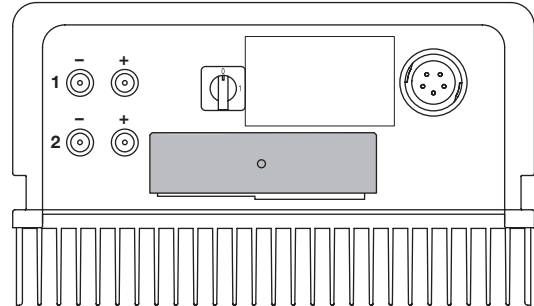

To open the connection box, loose the centre screw. Then carefully pull way the box toward the front.

After you have installed the connection cable, close the box again by guiding the locking hooks into the notches in the housing and then pressing the box onto the housing.

Retighten the mounting screw.

Interface overview

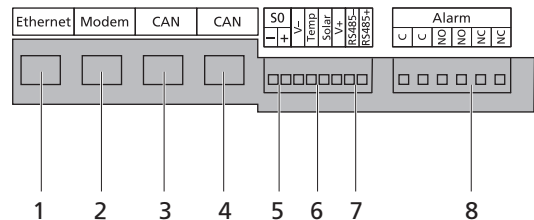

- 1 Ethernet connection
- 2 Modem connection
- 3 CAN bus
- 4 S0 interface (pulse output, e.g. for large display)
- 5 Connection for temperature and irradiation sensor
- 6 RS485 interface
- 7 Connection for alarm relay

Networking Solar Inverters via CAN bus

Solar Inverters from the NT, AT und PT series can be networked via the CAN bus interface. Use the included Ethernet cable to network the Solar Inverters with each other. Connect a terminating resistor at the first and last Solar Inverter in the series. The pluggable terminating resistors are included in the delivery.

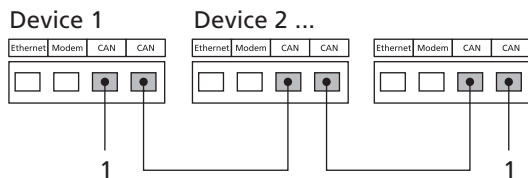

1 Terminating resistor

The total length of the CAN bus depends on the selected bit rate. The following table shows the possible bit rates and the resulting bus lengths.

Bit rate	Bus length
100 kbit/s	650 m
125 kbit/s	500 m
250 kbit/s	250 m
500 kbit/s	100 m

Solar Inverters of the PT series are delivered with a default setting of 125 kbit/s. The default setting for Solar Inverters of the NT and AT series is 500 kbit/s.



When Solar Inverters from different series are networked the bit rate in all units must be identical. The rate can be set via the Solar Inverter display or the Sunways Browser.

Setting the bit rate via the display menu:
«Settings – Network – CAN Bus – Baud rate»

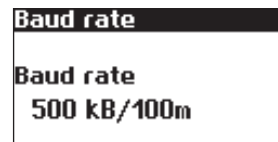
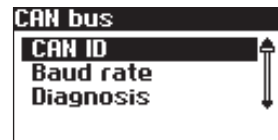

Up to 99 NT, PT and AT series units can be networked via a CAN bus. The following table shows the recommended cable cross-sections depending on the bus length and the number of nodes:

Bus length / Number of nodes	32	64	100
100 m	0,25 mm ² or AWG 24	0,25 mm ² or AWG 24	0,25 mm ² or AWG 24
250 m	0,34 mm ² or AWG 22	0,5 mm ² or AWG 20	0,5 mm ² or AWG 20
500 m	0,75 mm ² or AWG 18	0,75 mm ² or AWG 18	1,0 mm ² or AWG 16

3 Installation

In cases where the values specified in the table cannot be adhered to, a CAN bridge for boosting the signal must be installed, through which the length of the CAN bus can be extended by up to 500 m. The requirement to install a CAN bridge is therefore determined by the bus length, the number of nodes and the cable cross-sections.

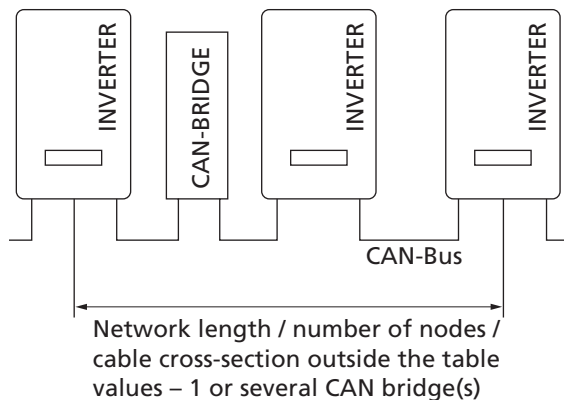

The CAN bridge is available from Sunways. For further information please contact the Technical Hotline.

The CAN bridge subdivides the bus into two physically independent segments. The maximum cable length of each segment is determined by the set bit rate. With a bit rate of 125 kbit/s two segments with a maximum length of 500 m each are possible. The total line length can therefore be up to 1 km under ideal conditions.

In systems with Solar Inverters from the PT series the CAN bridge can be integrated directly in the PT Solar Inverter and supplied via the 24 V DC power supply unit of the inverter. In systems with AT Solar Inverters and units from the new NT series (900 V) the CAN bridge can be integrated in the AC distribution. In this case an external 24 V DC supply is required (power consumption 1.5 W).

Networking Solar Inverters via RS485 interface

For joint monitoring of a solar system with Sunways Solar Inverters from the older NT generation (750 V or 850 V) you can use the RS485 interface integrated in the Solar Inverters. The system networked with the RS485 interface can be monitored with the Sunways Communicator.



- Use a twisted two-wire cable to network the Solar Inverters with each other.
- Mount the terminating resistor on the last Solar Inverter.
NT 8000/10000: Jumper **RS485MATCH**
NT 2600...NT 6000: Jumper **JP400**

Networking via RS485 interface

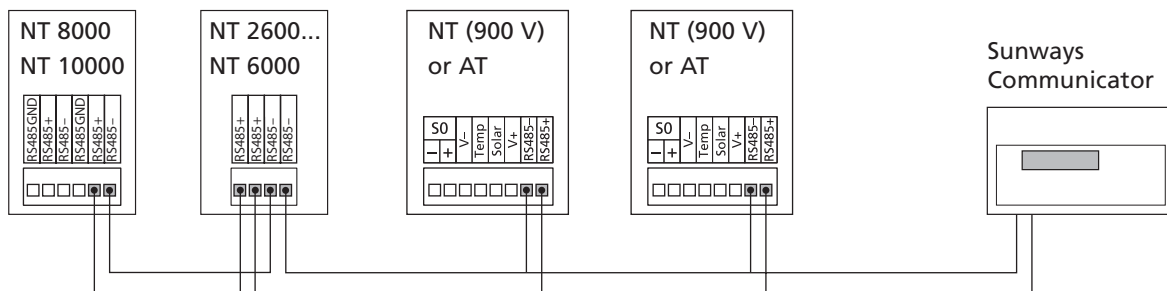

S0 interface

The S0 pulse output enables, for example, the connection of a large display (Sunways Display) for displaying the momentary output, the energy yields and the CO₂ reduction.

You can use the S0 interface on the master if you want to transmit the entire line yields as a sum to a large display.

The S0 interface is adjusted via the display on the inverter. Go to the menu «Settings – Network – Interfaces».

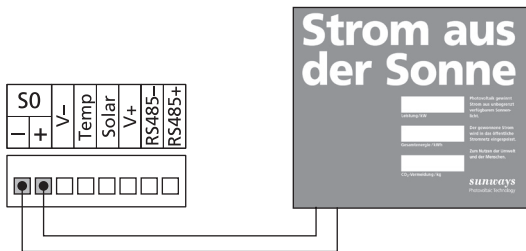
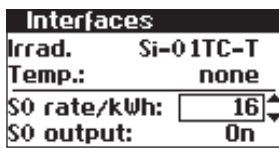

- Please note that the maximum pulse rate may not be greater than 15 pulse/sec. Calculate the pulse rate depending on the size of the solar system using the following formula:

$$\text{Pulse rate [pulses/kWh]} = \frac{50,000}{\text{system size [kWp]}}$$

- The pulse rate must be set on your Solar Inverter and on the large display.

Connection of temperature and irradiation sensor

The optional addition of an irradiation sensor (model Si-01TC-K from Ingenieurbüro Mencke & Tegtmeyer) with an integrated PT-100 temperature sensor for temperature measurement enables the acquisition of irradiation data and the corresponding module temperature and storage in the internal data memory as a 5-minute mean value. This additional measuring device helps analyse the system output. Based on the values, any errors on the PV generator, e.g. shading or failure of solar cells, can be detected.

The sensor is activated via the display. In the menu «Settings – Network – Interfaces» you can select the sensor type in the «Irrad.» and «Temp.» field.

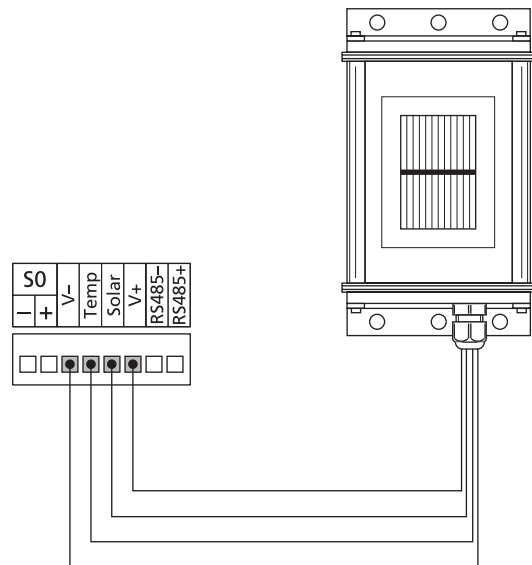
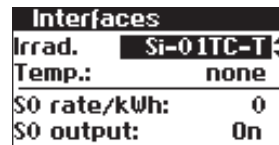

Assignment of sensor connection

Sensor connector pin assignment	Sensor connection designation	Solar Inverter connection
Pin 1	Plus signal temperature	Temp
Pin 2	Plus signal irradiance	Solar
Pin 3	Reference earth	V-
Pin 4	Plus connection for supply +5V	V+

Connecting alarm relay

The Solar Inverters are equipped with a potential-free alarm relay as standard. The relay can be designed as a make-contact element or as a break-contact element and is actuated for all malfunctions signalled by the device. This ensures a faster, more reliable indication of a possible fault in the PV system on site. For PV systems with several Solar Inverters, the individual relays can be switched in parallel and connected via a common indicator lamp.

The master also signals faults from other devices in the CAN network via the alarm relay. It is therefore sufficient for simple alerting to connect the alarm relay of the master.



CAUTION

The alarm relay is designed for 230 V/2 A. Higher outputs/voltages can result in the relay being destroyed. The connected signalling device must be fused separately. The terminals are intended for a cable cross-section of 0.2 mm² to 1.5 mm². When dimensioning the cross-section, also take the current consumption of the connected signalling device into account.

Wiring diagram for a single device

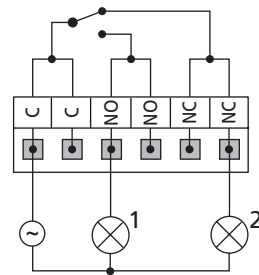

Wiring diagram for several devices

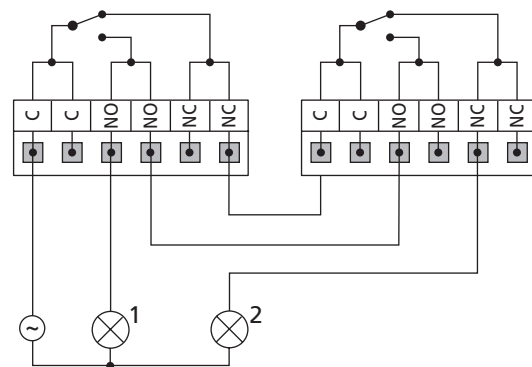

- 1 Indicator lamp, red
- 2 Indicator lamp, green



The Solar Inverter is supplied by the feed-in phase from the AC grid. If the feed-in phase fails the alarm relay cannot switch, even in the event of a fault.

4 Commissioning

4.1 Connecting and disconnecting Solar Inverter



CAUTION

- Ensure proper mechanical and electrical installation before commissioning the Solar Inverter.
- Check the proper condition of the electrical lines.
- Always separate the grid connection first by switching off the corresponding mains fuse and then the solar generator side by quickly opening the DC load break switch.
- The Tyco Solarlok connectors of the solar generator connection may not be disconnected while under load. The DC load break switch must be quickly switched to the switching position 0.



The Solar Inverter is supplied from the grid. The Solar Inverter switches on automatically when sufficient solar generator output is available. Corresponding switch-on and switch-off thresholds have been defined for this purpose.

Connecting

1. Switch on the grid connection with the external circuit breakers.
2. Switch on the solar generator voltage by quickly closing the DC load break switch (switching position 1). The Solar Inverter takes up operation when sufficient input voltage is available.

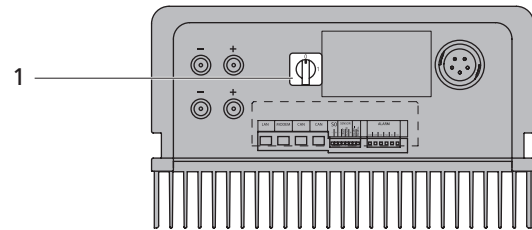

- 1 DC load break switch

The operating LED lights up in accordance with the operating state.

The commissioning menu opens when the Solar Inverter is connected for the first time.

Switching off

1. Open the grid connection by switching off the circuit breaker.
2. Disconnect the solar generator side by quickly opening the DC load break switch (switching position 0)

4.2 Commissioning

The commissioning menu is automatically opened the first time the Solar Inverter is connected. It helps you make the standard settings.



For a better understanding of keyboard operation, please also see the chapter Operation.

The commissioning of the Solar Inverter as

- a single device
- a master and slaves with several networked devices

is described in detail in the following.

Commissioning single device

System with one Solar Inverter

Single device

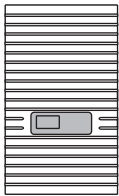

1. During initial start-up the following appears on the display:

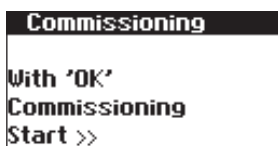

Start commissioning with **ok**.

2. Select required language with **▲** / **▼**

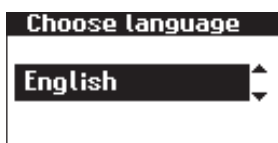

Confirm selected language with **ok**.

3. Select the country **▲** / **▼**.



Confirm the country of installation.



Your Solar Inverter will only start feeding electricity once the country of installation has been confirmed.

4. Select «Single device» with **▲** / **▼**.



Confirm with **ok**.

5. Set date and time.



Please proceed with caution for time settings, as they directly affect data logging. For example, if you set the time back by 1 hour, then the existing data for the last hour will be overwritten.

Select date with **ok**. Change selected number with **▲** / **▼** and jump to next number with **◀** / **▶**.

Save the set date with **ok** then set the time accordingly.

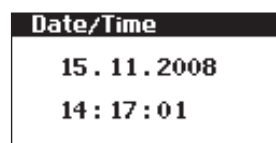





Save the set time with **ok**.

4 Commissioning

6. Set password. Select password

Default password is:

* * * * *

A new password can be set with  /  /  / 
as an option.



Please note:

Numerals from 0 – 9 and letters from a – z and from A – Z are admissible.

The password always has 8 characters. If the password you choose is fewer than 8 characters in length, the remainder, up to the full 8 characters, is filled with "*" symbols.

For example:

You choose "Solar" as your password. This password has 5 characters. The system therefore then automatically adds three "*" symbols, meaning that your password becomes "Solar***".



Confirm password with .

7. Completion of commissioning



Confirm overview with .

Commissioning several networked devices

System with several Solar Inverters

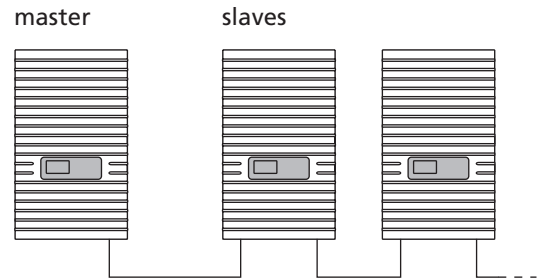

Before commissioning, all devices must be interconnected via the CAN bus interface. See section Networking Solar Inverters via CAN bus.

Switch on all devices following installation. Commissioning begins with the master you have selected.

Compatibility between Sunways Solar Inverters

The following table provides an overview of which devices can be networked with each other and how, and lists any special considerations:

	NT Series (900 V)	PT series	AT series	NT series (850 V)
NT series (850 V)	with RS485: <ul style="list-style-type: none"> · Sunways Portal: with Sunways Communicator 	NT with RS485 / PT with CAN bus: <ul style="list-style-type: none"> · Sunways Portal: connect NTs with Sunways Communicator, PTs with Sunways Modem or DSL/network to the Internet · Sunways Browser: only available for PT 	with RS485: <ul style="list-style-type: none"> · Sunways Portal: with Sunways Communicator · Sunways Monitor 	with RS485: <ul style="list-style-type: none"> · Sunways Portal: with Sunways Communicator · Sunways Monitor: with interface converter
AT series	with separate CAN networks: <ul style="list-style-type: none"> · Sunways Browser · Sunways Portal: NT devices (900 V) must be operated in a separate CAN network with independent main unit 	with CAN bus: <ul style="list-style-type: none"> · Sunways Browser · Sunways Portal · The PT Solar Inverter must be the main unit. 	with CAN bus: <ul style="list-style-type: none"> · Sunways Browser · Sunways Portal 	
PT series	with separate CAN networks: <ul style="list-style-type: none"> · Sunways Browser · Sunways Portal: NT devices (900 V) must be operated in a separate CAN network with independent main unit 	with CAN bus: <ul style="list-style-type: none"> · Sunways Browser · Sunways Portal 		
NT Series (900 V)	with CAN-Bus (CANopen/CiA437): <ul style="list-style-type: none"> · Sunways Browser · Sunways Portal 			



In mixed systems containing AT and PT Solar Inverters, the Solar Inverter PT is always the master.

Commissioning the master

1. During initial start-up the following appears on the display:



Start commissioning with **ok**.

2. Select required language with **▲** / **▼**.

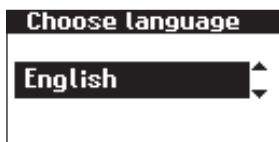

Confirm selected language with **ok**.

3. Select the country **▲** / **▼**.



Confirm the country of installation.



Your Solar Inverter will only start feeding electricity once the country of installation has been confirmed.

4. Select «Master» with **▲** / **▼**.



Confirm with **ok**.



The other devices in the CAN network are automatically configured as slaves.

5. Set the data and time centrally for all connected devices.



Please proceed with caution for time settings, as they directly affect data logging. For example, if you set the time back by 1 hour, then the existing data for the last hour will be overwritten.

Select date with **ok**. Change selected number with **▲** / **▼** and jump to next number with **◀** / **▶**.

Save the set date with **ok** then set the time accordingly.

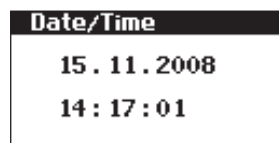

Save the set time with **ok**.

6. CAN network list is set up.



Depending on the size of the network, it may take a moment until the master has found all slaves and added them to the list.



Devices = total number of devices found in CAN network, including master

In network = number of configured devices, including master

After the master has found all connected slaves, these must be configured before commissioning of the master is continued. The device list is updated and extended whenever a slave is configured.

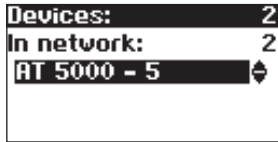

Confirm with **ok**.

7. Set password. Select password **ok**

Default password is:

A new password can be set with **▲** / **▼** / **◀** / **▶** as an option.



Please note:

Numerals from 0 – 9 and letters from a – z and from A – Z are admissible.

The password always has 8 characters. If the password you choose is fewer than 8 characters in length, the remainder, up to the full 8 characters, is filled with "*" symbols.

For example:

You choose "Solar" as your password. This password has 5 characters. The system therefore then automatically adds three "*" symbols, meaning that your password becomes "Solar***".



Confirm password with **ok**.

8. Completion of commissioning



Confirm overview with **ok**.

Commissioning slaves

After a master has been defined, the display for requesting the CAN-ID is automatically shown on the display on each slave.

1. Request CAN ID. Request next highest free ID from master with **▲** or next lowest free ID with **▼**. The master assigns a free ID to the slave. Confirm the ID with **ok** within 5 seconds.

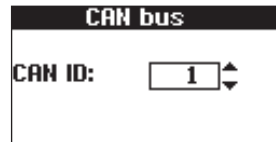

Request further IDs **▲** / **▼**.

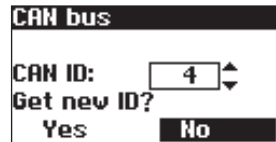

Confirm CAN ID with **ok** within 5 seconds.



- The data for the individual slaves can be assigned in the Sunways Browser and in the menu of the master based on the IDs.
- The CAN-ID 1 is automatically assigned to the master. This means the slaves can be assigned IDs between 2 - 99.
- Commissioning cannot continue until an ID has been requested from the master.

2. Completion of commissioning



Confirm overview with **ok**.

3. Carry out commissioning for all other slaves as described above.

Later commissioning

If you add new devices or replace existing ones in your solar system, then you can display the device list in the display on the master under «Settings – Network – CAN bus». The new device can then be put into operation in accordance with the description for commissioning slaves.

5 Operation

5.1 Operating elements

Operating field

The Solar Inverter is operated via the operating field on the front.

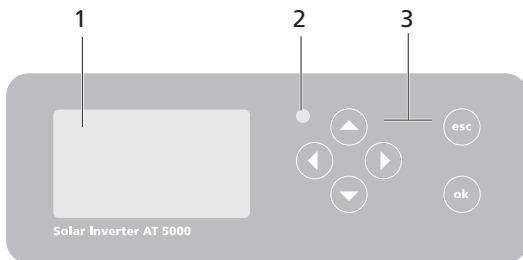

- 1 LCD display (lighted)
- 2 Operating LED
- 3 Keyboard

LCD display

A graphics-capable, monochrome dot matrix display is integrated in the operating field. In standard operation the momentary output, daily yield and status are displayed. The bar graph shows the energy feed-in of the current day.

Press any key to activate the display lighting. If no key is pressed for approx. 1 minute, the display lighting goes out.



Important!

The LCD display is not a calibrated measuring device. It is characterised by a slight, system-dependent difference of a few percent. Exact accounting of the data with the power supply company requires a calibrated meter.

Keyboard

The keyboard can be used to navigate in the menu, edit text fields, select entries from lists and enter numbers consecutively and digit by digit. User entries can only be made if the value to be changed is selected. The cursor changes visibly in the editing mode and indicates the digit to be changed.

- key Scroll up.
- key Scroll down.
- key Select menu item..
- key Back one menu level.
- key Select menu item and confirm your entries.
- key Cancel.

Operating LED

The combined red/green LED indicates the device status of the Solar Inverter:

- LED off
Solar Inverter is not active (night mode)
- LED green, continuously lit
Solar Inverter is active and feeds into power grid (MPP mode)
- LED green, flashing
Solar Inverter is active and feeds into power grid, however with current, output or temperature limitation.
- LED red, continuously lit
an error has occurred (malfunction)
- LED red, flashing
a warning has been issued

Standard screen (single device)

The standard screen is always shown when no keyboard entry is made for more than 1 minute. It can also be called up manually with the menu item «Solar Inverter – Instantaneous Values».

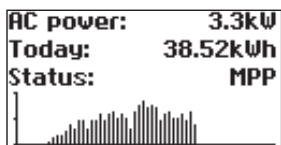

The standard screen shows the main data at a glance. The first line shows the current feed-in power. The second line shows the energy fed in during the current day.

The status line indicates the device status with the following messages:

- MPP Feeding in MPP mode
- AC cur.lim. Feeding with AC current limitation
- DC cur.lim. Feeding with DC current limitation
- Temp.lim. Feeding with temperature limitation
- Output lim. Feeding with output limitation
- Feed. Feeding
- Warning A warning is active
- Error An error has occurred
- Night Night mode
- Start Device initialisation phase
- COM-Upd The communication software is being updated
- DSP-Upd The control software is being updated

The graphic in the lower section of the screen shows the output curve for the current day as a bar graph. The current period is shown as a flashing bar, as it is still increasing.

Standard screen (system)

This screen shows the system data for a CAN-networked system.

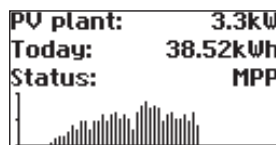

Next to the total current system output, you also see the energy yield of your solar system and any status messages of all connected devices. These are provided with the inverter number. «M» means that the error has occurred in the master.



- The various functions are accessed via the menu. The main menu is opened from the standard screen by pressing **esc** twice.
- You can always return to the standard screen by pressing and holding the **esc** key.
- If a status message is shown, then you can open the error list directly with **ok**.
- You can access other instantaneous values from the standard screen with **▼** and **▲**.

5.2 Access rights

Operation of the Solar Inverter is divided into various areas protected with passwords.

The password has 8 digits or characters.

The password can be entered in the menu item «Settings – Login».



After a correct password entry the login remains active for 5 minutes. The device then switches back to guest mode. Pressing any key during the login period extends resets the period to > 5 minutes.

Customer area

The customer password must be entered to access this area. All settings can be made which are required for installation and commissioning of the Solar Inverter.



- The password for the customer area is:
* * * * * *
- The password is preset and is directly confirmed with .
- As an option you can assign a personal password in the Commissioning menu. Digits between 0 – 9 and letters between a – z and A – Z are permitted.
- The password always has 8 characters. If the password you choose is fewer than 8 characters in length, the remainder, up to the full 8 characters, is filled with "*" symbols.
- For example:
You choose "Solar" as your password. This password has 5 characters. The system therefore then automatically adds three "*" symbols, meaning that your password becomes "Solar***".

Installer area

In this area the installer can make special settings on the Solar Inverter which are available after consulting the Technical Hotline. Request a device-specific password from the Technical Hotline. These passwords are only relevant for the Sunways Browser. All commissioning procedures are accessible from the customer area.

Technical Hotline +49 (0)7531 996 77-577





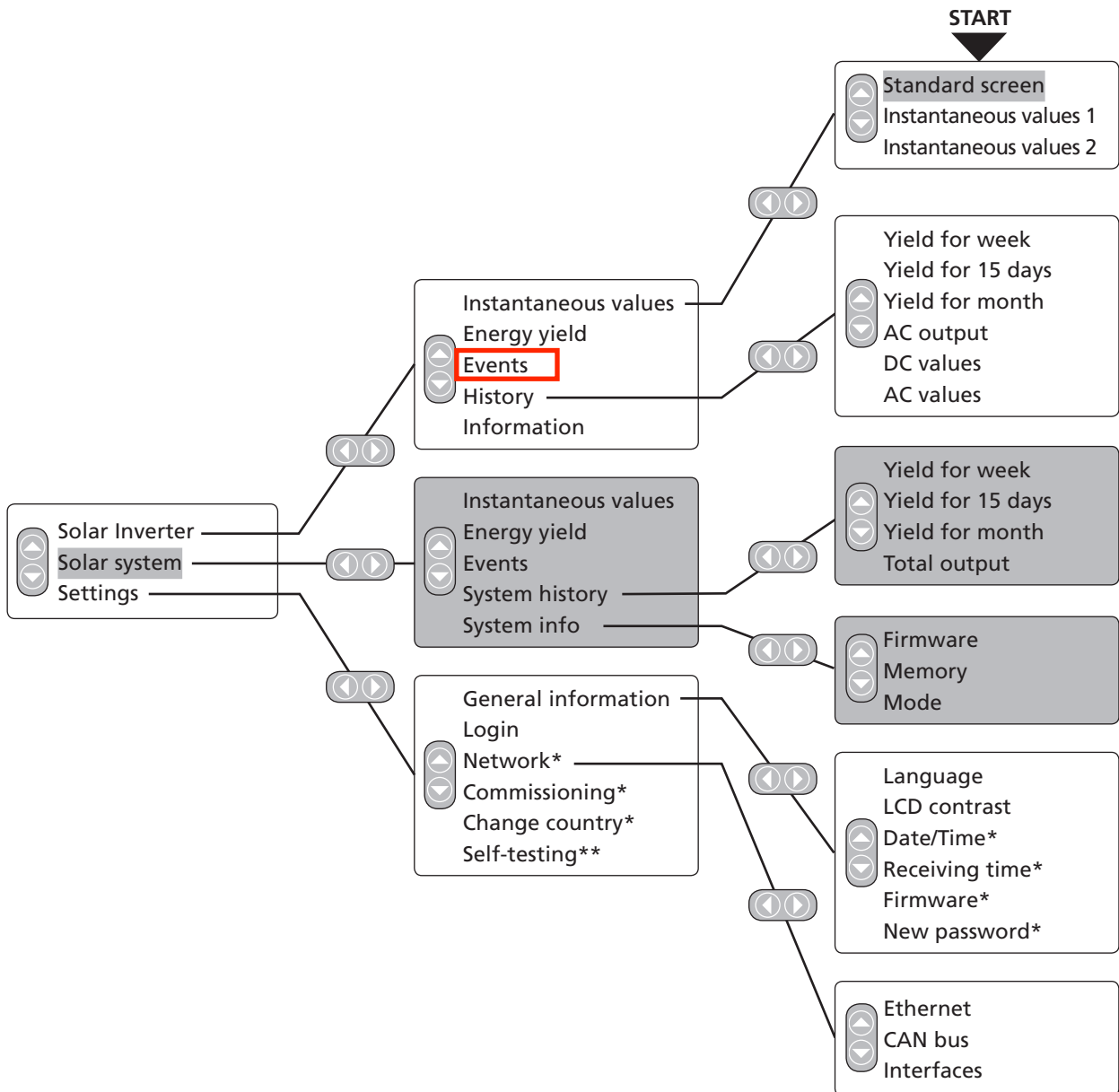

5.3 Menu structure

The menu provides access to all Solar Inverter screens. Open the main menu by pressing the left arrow key twice from the standard screen.

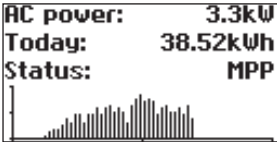

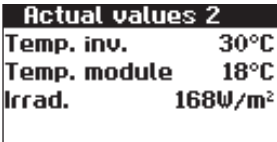
- The areas highlighted in grey are only available in the master
- *) after entry of customer password
Standard password: ***** (= 8 times star key)
- **) This is only shown if the configured country of installation is Italy.

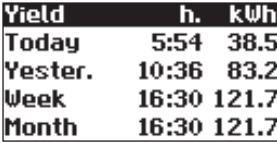
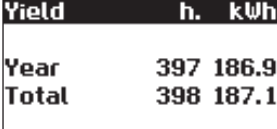
5.4 Overview of screen displays

Display	Description	Menu selection
Instantaneous Values – Device		
	<p>Current feed-in power, daily energy yield and device status MPP:Feeding in MPP mode</p>	<p>The screen appears automatically when you have not made any entries with the keyboard for several minutes.</p> <p>Solar Inverter – Instantaneous values</p>
	<p>Display of voltages and currents from solar generator and grid</p>	<p>Solar Inverter – Instantaneous values – </p>
	<p>Interior temperature of device (Temp. Inv.) and temperature and irradiation values (if sensor is connected)</p>	<p>Solar Inverter – Instantaneous values – </p>
	<p>AC yields and operating hours from today, yesterday, week and month</p>	<p>Solar Inverter – Energy yield</p>
	<p>AC yields and operating hours from year and total value</p>	<p>Solar Inverter – Energy yield – </p>

Display	Description	Menu selection
---------	-------------	----------------

Events – Device

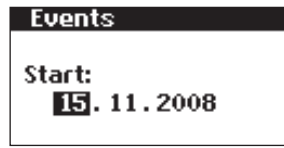

Select starting data for event display

Solar Inverter – Events

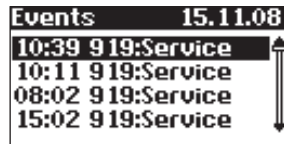

Display event list

Solar Inverter – Events – **ok**

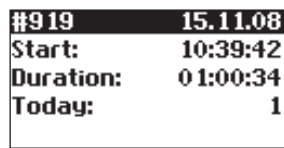

Display event details (error number, data, starting time, duration and number of occurrences per day)

Solar Inverter – Events – **ok** – **ok**

History – Device

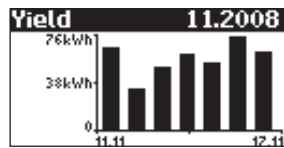

Daily yield for 1 week

Solar Inverter – History – Yield for week

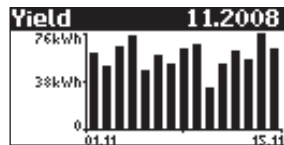

Daily yields for 15 days

Solar Inverter – History – Yield for 15 days

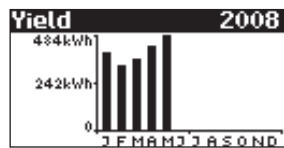

Monthly yields

Solar Inverter – History – Yield for month

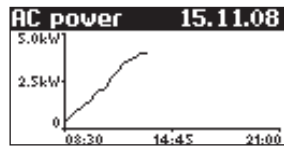

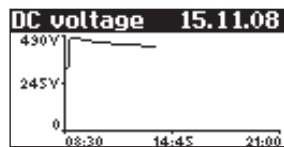

AC output (5-min. values)

Solar Inverter – History – AC output

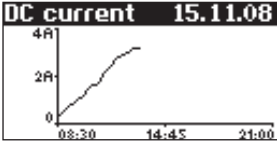
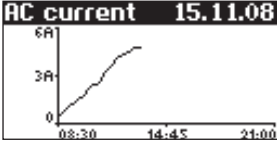
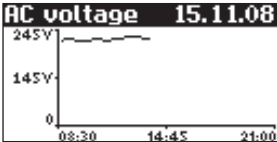

DC voltage (5-min. values)

Solar Inverter – History – DC output

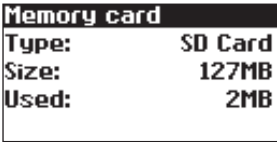
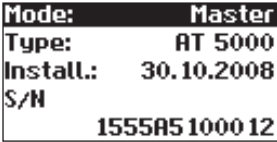
Display	Description	Menu selection
	DC current (5-min. values)	Solar Inverter – History – DC values – ▼
	AC current (5-min. values)	Solar Inverter – History – AC values
	AC voltage (5-min. values)	Solar Inverter – History – AC values – ▼
Information – Device		
	Firmware	Solar Inverter – Information – Firmware
	Memory card	Solar Inverter – Information – Memory
	Device mode	Solar Inverter – Information – Mode

Instantaneous values – Solar system (only on master)

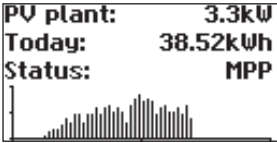
	Current system feed-in power, daily energy yield and system status	The screen appears on the master automatically when you do not make any entries with the keyboard for several minutes. Solar system – Instantaneous values
---	--	---

Display	Description	Menu selection
---------	-------------	----------------

Yields – Solar system (only on master)

	AC system yields and operating hours from today, yesterday, week and month	Solar system – Energy yield
---	--	-----------------------------

	AC system yields and operating hours from year and total value	Solar system – Energy yield – ▾
---	--	---------------------------------

Events – Solar system (only on master)

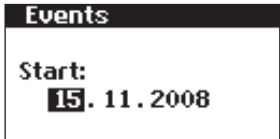
	Select starting data for system event display	Solar system – Events
---	---	-----------------------

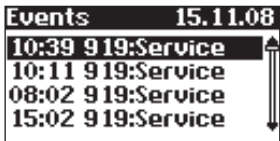

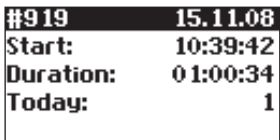

	Display event list for entire system	Solar system – Events – ok
---	--------------------------------------	----------------------------

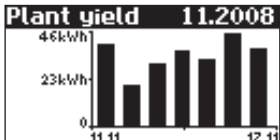

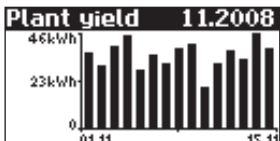
	Display event details (error number, data, starting time, duration and number of occurrences per day)	Solar system – Events – ok – ok
---	---	---------------------------------

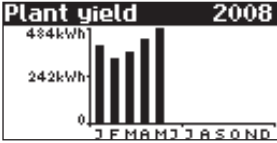
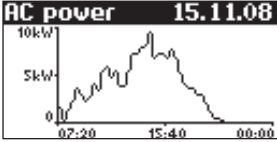
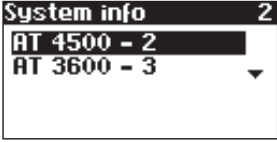
History – Solar system (only on master)

	Solar system daily yield for 1 week	Solar system – History – Yield for week
---	-------------------------------------	---

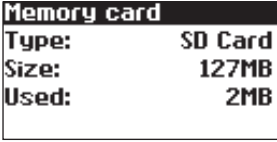
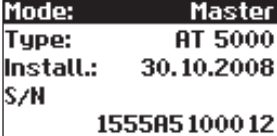
	Solar system daily yield for 15 days	Solar system – History – Yield for 15 days
---	--------------------------------------	--

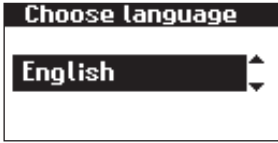
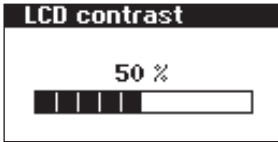
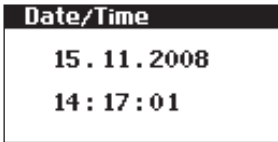
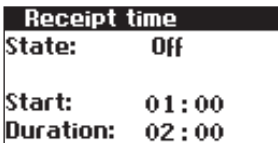
Display	Description	Menu selection
	Solar system monthly yields	Solar system – History – Yield for month
	Solar system AC output (5-min. values)	Solar system – History – AC output
System info – Solar system (only on master)		
	Device list for selecting a device	Solar system – System info
	Selection of information	Solar system – System info – 
	Firmware	Solar system – System info – Firmware
	Memory card	Solar system – System info – Memory
	Device mode	Solar system – System info – Mode

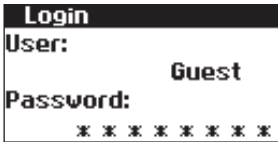
Display	Description	Menu selection
Settings – General		
	Display language	Settings – General – Language
	LCD contrast	Settings – General – LCD contrast
	Set date/time (only possible with customer password)	Settings – General – Date/Time
	Set receiving time (starting time and duration in which the device can also be addressed in the night mode via the network). (only possible with customer password)	Settings – General – Receiving time
	Changing the customer password (only possible with customer password)	Settings – General – Password
Settings – Login		
	Password entry to access advanced settings (necessary for commissioning)	Settings – Login

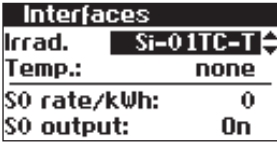
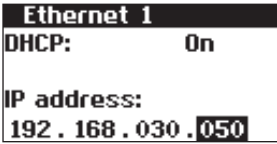
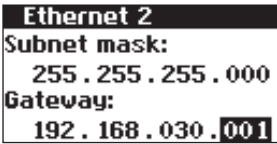
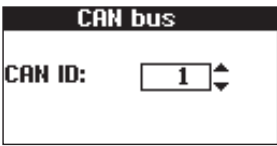
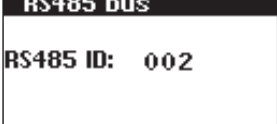
Display	Description	Menu selection
Settings – Network (only possible with customer password)		
	Setting of the irradiation and temperature sensor and configuration of the S0 pulse output	Settings – Network – Interfaces
	Network settings (Screen 1): Activate DHCP for the automatic IP address setting or enter IP address manually	Settings – Network – Ethernet
	Network settings (Screen 2):	Settings – Network – Ethernet – ▼
	Have CAN bus ID assigned by the master	Settings – Network – CAN bus
	Assign RS485 address to the device (only necessary if NT devices are connected in the network)	Settings – Network – RS485 bus

5.5 Malfunction displays



The Solar Inverter indicates malfunctions in the LCD display and saves these in the internal error memory.

The malfunction display consists of a number and a short designation. Based on the first number you can quickly recognise which area the error has occurred in:

- 1: Error in the area of the solar generator
- 2: Error in the area of the AC network
- 3: Error in the area of the inverter
- 4: Error in the area of the interfaces/communication
- 9: Service error

If an error is shown in the standard display, then you can look up the exact error message in the menu under «Solar Inverter – Events».

- A restart may be attempted in the event of an error message.
- Please note the serial number of the device and the error number before contacting the Technical Hotline.
- The Technical Hotline can be contacted on +49 (0)7531 996 77-577 during weekdays.

Display message	Description	Cause and possible remedies
Solar generator fault		
101:U-DC max	Your AT Solar Inverter is approved for a maximum open-circuit voltage of the solar generator of 680 V. All components of the DC input are sufficiently dimensioned with a safety factor. If the threshold is exceeded, the Solar Inverter stops feeding.	<p>The maximum DC voltage was exceeded.</p> <ul style="list-style-type: none"> · Check the dimensioning of your PV generator. <p>Too many modules are connected in series.</p> <ul style="list-style-type: none"> · Reduce the number of modules and carry out commissioning again.
102:Insulat.	Before each connection, your Solar Inverter checks the PV system for a possible earth fault or insulation faults. Should this kind of error be detected, no feeding takes place. The mode of operation is conformant with DIN VDE 0126-1-1.	<p>The Solar Inverter has discovered an insulation fault in the PV system during start-up.</p> <ul style="list-style-type: none"> · Check your PV system for possible insulation faults (pinched-off DC lines etc). <p>The measured insulation resistance must be at least 680 kohms.</p>

Display message	Description	Cause and possible remedies
103:AFI>30mA	Your Solar Inverter is equipped with a universally sensitive AFI according to DIN VDE 0126-1-1. This monitoring device has detected a relative residual current jump of >30 mA.	<p>A residual current jump has occurred during operation of the Solar Inverter.</p> <ul style="list-style-type: none"> · Check your PV system for possible insulation faults.
104:AFI>0.3A	Your Solar Inverter is equipped with a universally sensitive AFI according to DIN VDE 0126-1-1. This monitoring device has detected an absolute fault current of > 300 mA.	<p>A residual current has occurred during operation of the Solar Inverter.</p> <ul style="list-style-type: none"> · Check your PV system for possible insulation faults.
AC network fault		
201:Surge e.	Your Solar Inverter continually monitors the quality of the AC grid. During high voltage peaks on the phase feeding in, the Solar Inverter stops feeding and attempts a restart.	<p>The Solar Inverter has detected a high voltage peak on the phase feeding in.</p> <ul style="list-style-type: none"> · After malfunction elimination the Solar Inverter restarts automatically. Should the error occur frequently, please contact your power supply company. <p>A monitoring phase and a directly earthed conductor were exchanged when connecting the AC side.</p>
202:UAC1>10%	If the voltage of the phase feeding in was greater than 253 V for a period of ten minutes, the Solar Inverter stops feeding and attempts to switch on again when the grid voltage is within the permissible range. The mode of operation is conformant with DIN VDE 0126-1-1.	<p>The cable cross-section in the AC supply line to the Solar Inverter is too small.</p> <p>Your inverter feeds into a spur line, which is insufficiently dimensioned.</p> <ul style="list-style-type: none"> · Check the design of your grid connection (energy meter) or the grid feed point to your Electric Utility. · Ask your Electric Utility about grid stability and design.

Display message	Description	Cause and possible remedies
203:UAC1>Max 205:UAC2>Max 207:UAC3>Max	Your Solar Inverter continually monitors the voltage level of the phases L1, L2 and L3. When the maximum permissible limit is exceeded, the Solar Inverter stops feeding and does not start up again until the voltage value drops below the maximum permissible limit.	The cable cross-section in the AC supply line to the Solar Inverter is too small. Your inverter feeds into a spur line, which is insufficiently dimensioned. <ul style="list-style-type: none"> · Check the design of your grid connection (energy meter) or the grid feed point to your Electric Utility. · Ask your Electric Utility about grid stability and design.
204:UAC1<Min 206:UAC2<Min 208:UAC3<Min	Your Solar Inverter continually monitors the voltage level of the phases L1, L2 and L3. When the minimum permissible limit is dropped below, the Solar Inverter stops feeding and does not start up again until the voltage value exceeds the minimum permissible limit. If the voltage drops below 160 V, the Solar Inverter cannot be supplied.	<ul style="list-style-type: none"> · Ask your Electric Utility about grid stability and design.
209:Isol.op.	Your Solar Inverter is equipped with a high-quality redundant grid monitoring function according to DIN VDE 0126-1-1 and constantly monitors the grid. If one of the phases fails, or if the phase position between the individual conductors changes, the Solar Inverter stops feeding and does not start up again until the error is eliminated.	<ul style="list-style-type: none"> · Check the phases L2 and L3. · Ask your Electric Utility about grid stability and design.
210:Frq1>Max 211:Frq1<Min	The Solar Inverter continually monitors the grid frequency of the phase feeding in. If this lies above the permissible value, the Solar Inverter stops feeding and does not start up again until the value is below the limit.	<ul style="list-style-type: none"> · Ask your Electric Utility about grid stability and design.
212:DC share	Your Solar Inverter continually monitors the quality of current fed in. If an increased DC share is found in the current fed in, the Solar Inverter stops feeding. The Solar Inverter does not attempt to feed in again until after a reset (the next day).	<ul style="list-style-type: none"> · Restart the Solar Inverter. If the error still occurs, please contact the technical hotline. The phone number is provided on the back of the manual.

Display message	Description	Cause and possible remedies
213:UAC1>10% (Warning)	The voltage of the phase feeding in is higher than 10% above the nominal value. If this is the case for longer than ten minutes, the inverter stops feeding and does not switch on again until the voltage drops below this limit again.	<p>The cable cross-section in the AC supply line to the Solar Inverter is too small.</p> <p>Your inverter feeds into a spur line, which is insufficiently dimensioned.</p> <ul style="list-style-type: none"> · Check the design of your grid connection (energy meter) or the grid feed point to your Electric Utility. · Ask your Electric Utility about grid stability and design.
224:AC P. fail	Your Solar Inverter has detected a mains power failure.	<ul style="list-style-type: none"> · Ask your Electric Utility about grid stability and design.
225:ULL err	Your Solar Inverter is equipped with a high-quality redundant grid monitoring function according to DIN VDE 0126-1-1 and constantly monitors the grid. If one of the phases fails, or if the phase position between the individual conductors changes, the Solar Inverter stops feeding and does not start up again until the error is eliminated.	<ul style="list-style-type: none"> · Check phases L2 and L3. · Ask your power supply company (PSC) about grid stability and design.
Inverter fault		
301:AFI over	The integrated sensor for measuring the residual current has been operated outside its measuring range.	<p>A residual current was detected during start-up.</p> <ul style="list-style-type: none"> · Restart the Solar Inverter. <p>If the error still occurs, please contact the technical hotline. The phone number is provided on the back of the manual.</p>
302:Monit.	The AT Solar Inverter is equipped with a redundant monitoring device which constantly checks the measured values of the controller for plausibility. If a deviation or an error is detected in the process, this message appears. In addition, this message can also appear in case of a power failure.	<ul style="list-style-type: none"> · Restart the Solar Inverter. <p>If the error still occurs, please contact the technical hotline. The phone number is provided on the back of the manual.</p>

Display message	Description	Cause and possible remedies
303:Overtmp.	<p>Your Solar Inverter is designed for an ambient temperature of up to +40°C. When a specified temperature threshold of the heat sink is reached, the output power is reduced linearly. Should the heat sink temperature nevertheless continue to increase, feeding is stopped. After the heat sink temperature drops, the Solar Inverter starts up again automatically.</p>	<p>The maximum permissible ambient temperature has been exceeded.</p> <ul style="list-style-type: none"> · The installation location is not suitable. Please find another installation location. <p>The necessary air circulation was not taken into account during installation.</p> <ul style="list-style-type: none"> · Clean the Solar Inverter, if dirt prevents cooling. · Observe the installation distances specified in the manual. <p>Objects were laid on the heat sink and unimpaired convection was prevented.</p> <ul style="list-style-type: none"> · Remove the objects.
304:Grid re.	<p>The AT Solar Inverter checks the operation of the mains relay prior to every switch-on. An error was detected during this check.</p>	<ul style="list-style-type: none"> · Restart the Solar Inverter. <p>If the error still occurs, please contact the technical hotline. The phone number is provided on the back of the manual.</p>
305:AFI test	<p>The AT Solar Inverter checks the operation of its residual-current monitoring device prior to every switch-on. An error was detected during this check.</p>	<ul style="list-style-type: none"> · Restart the Solar Inverter. <p>If the error still occurs, please contact the technical hotline. The phone number is provided on the back of the manual.</p>
306:T. meas.	<p>The AT Solar Inverter is equipped with a temperature sensor that monitors the heat sink temperature. This message appears if the sensor reports a value outside its value range or in case of a sensor cable break.</p>	<p>The ambient temperature of the Solar Inverter is outside the permissible range (< -25°C).</p> <ul style="list-style-type: none"> · Wait until the temperature reaches the permissible operating range. <p>A cable break has occurred in the sensor which monitors the heat sink temperature.</p> <ul style="list-style-type: none"> · Please contact the technical hotline. The phone number is provided on the back of the manual.

Display message	Description	Cause and possible remedies
307:Overtmp. (Warning)	Your Solar Inverter is designed for an ambient temperature of up to +40°C. When a specified temperature threshold of the heat sink is reached, the output power is reduced linearly. Should the heat sink temperature nevertheless continue to increase, feeding is stopped. This warning appears when the current heat sink temperature is just below the switch-off threshold.	<p>The maximum permissible ambient temperature has been exceeded.</p> <ul style="list-style-type: none"> · The installation location is not suitable. Please find another installation location. <p>The necessary air circulation was not taken into account during installation.</p> <ul style="list-style-type: none"> · Clean the Solar Inverter, if dirt prevents cooling. · Observe the installation distances specified in the manual. <p>Objects were laid on the heat sink and unimpaired convection was prevented.</p> <ul style="list-style-type: none"> · Remove the objects.
310:no config	No country is set.	<p>Contact the technical hotline for the installer password. (The phone number is provided on the back of the manual.) Reset the country according to the explanatory note see 4.2 Commissioning on page 29</p>
Interface/communication fault		
401:SD card	The Solar Inverter cannot find an SD card.	<ul style="list-style-type: none"> · Restart the Solar Inverter. <p>If the error still occurs, please contact the technical hotline. The phone number is provided on the back of the manual.</p>
402:SD card	The SD card is write-protected.	<ul style="list-style-type: none"> · Restart the Solar Inverter. <p>If the error still occurs, please contact the technical hotline. The phone number is provided on the back of the manual.</p>
403:CAN user	Communication error with CAN user.	<ul style="list-style-type: none"> · Check whether an error has occurred in the CAN slave. Restart slave and master if necessary.

Display message	Description	Cause and possible remedies
404:CAN bus	CAN bus not in operation.	<p>No communication is possible via the CAN bus.</p> <ul style="list-style-type: none"> · Check the bus lines and the terminating resistors. · Check whether the maximum permissible line lengths have been complied with. · Check whether the bus lines have been routed parallel to power cables. Separate bus lines and power cable from each other spatially if necessary.
405:CAN user	CAN user does not respond.	<ul style="list-style-type: none"> · Check whether an error has occurred in the CAN slave. Restart slave if necessary.
406:Solar (Warning)	No sensor found on sensor channel 1 (solar).	<p>If you have connected a sensor:</p> <ul style="list-style-type: none"> · Check the connection to your sensor. <p>If you have not connected a sensor:</p> <ul style="list-style-type: none"> · Check the configuration with the Sunways Browser.
407:Temp. (Warning)	No sensor found on sensor channel 2 (temperature).	<p>If you have connected a sensor:</p> <ul style="list-style-type: none"> · Check the connection to your sensor. <p>If you have not connected a sensor:</p> <ul style="list-style-type: none"> · Check the configuration with the Sunways Browser.
408:CAN com. (Warning)	Communication malfunctions occur repeatedly on the CAN bus.	<p>A malfunction occurs in the data transmission on the CAN bus. However, a data exchange continues to be possible.</p> <ul style="list-style-type: none"> · Check whether all connectors of the bus lines and the terminating resistors are properly mounted. · Check whether the bus lines have been routed parallel to power cables. Separate bus lines and power cable from each other spatially if necessary.

Display message	Description	Cause and possible remedies
409:CAN cfg. (Warning)	CAN bus is in the configuration mode. No measured values are transferred.	At least one device is in the menu item «Settings – Network – CAN bus». · Close this menu for all devices.
410:SMTP ser	Warning: SMTP server cannot be reached (410).	Fault during e-mail delivery. Re-attempt e-mail delivery.
411:SMTP no soc	Warning: SMTP no socket available (411).	· If the fault recurs check the e-mail settings via the Sunways Browser
412:SMTP cm	Warning: SMTP faulty communication with server (412).	
413:DNS failed	Warning: DNS has failed (413).	Communication fault between the integrated web server and an Internet browser in conjunction with the Sunways Browser.
414:HTTP client	Warning: HTTP client connection has failed (414).	These warnings are non-critical and can be ignored if they only occur occasionally.
415:HTTP auth.	Warning: HTTP client authorisation has failed (415).	These warnings have no influence on the energy production of the inverter.
416:HTTP Tim.	Warning: HTTP client timeout (416).	
417:HTTP no soc	Warning: HTTP client no socket available (417).	
418:HTTP no socket	Warning: HTTP client error with socket (418).	
419:HTTP method	Warning: HTTP client incorrect method (419).	
420:HTTP protocol	Warning: HTTP client error with protocol (420).	
421:HTTP write error	Warning: HTTP client write error (421).	
422:HTTP read error.	Warning: HTTP client read error (422).	
424:Time syn (Warning)	Warning: Time synchronisation with the NTP server has failed.	Firewall port 123 is blocked. · Select an alternative time server.

Display message	Description	Cause and possible remedies
Service fault		
9xx: Service fault 9xx: Service warning	A service fault has occurred.	<ul style="list-style-type: none"> · Disconnect the Solar Inverter from the grid and from the solar generator and reconnect it. <p>If the error occurs again, please contact the Technical Hotline. The phone number is provided on the back of the manual.</p>

6 System monitoring

6.1 General information

The basis for the system monitoring is the data logger integrated in the AT Solar Inverter. The Solar Inverters of the AT series are equipped with a broad range of monitoring options for your solar system:

- The Sunways Browser offers the display of instantaneous values, stored operating data and settings.
- With active alerting the master can send errors which have occurred in the solar system to a selected recipient by Email.
- With the Sunways Portal connection the AT Solar Inverter can send the operating data of your solar system to the Sunways Portal daily without additional hardware. This enables you to track your yields via the Internet.

One of the four possible connections between a PC and the Solar Inverter is possible for this purpose:

- Direct connection via an Ethernet cable or internal network



The Solar Inverter is unable to send e-mails via a direct connection. Portal connection and active alerting is therefore not possible.

- Connection via the Internet, e.g. connection of the Solar Inverter to a DSL connection
- Connection via a Sunways Modem

6.2 Integrated data logger

The integrated data logger of the AT Solar Inverter stores the operating data of your solar system. In addition to 5-minute mean values, energy yields are also stored as 5-minute, daily, weekly, monthly and annual values. Up to 200 status changes (warnings and errors with start and end) are also stored. Each data record contains the data and time. The data logger is designed as a circulating memory, i.e. the respective oldest data are overwritten with new data.

Operating data (5-min. mean values)

Number	Value
2000	DC current
2000	DC voltage
2000	AC current
2000	AC voltage
2000	AC output
2000	Device temperature
2000	Module irradiance (optional)
2000	Module temperature (optional)

Energy yields

Number	Value
2000	5-minute yield
800	Daily yield
800	Weekly yield
250	Monthly yield
20	Annual yield

Status messages

Number	Value
200	Status changes

6.3 Direct Ethernet connection

The Solar Inverters are equipped with an Ethernet interface as standard for system monitoring and configuration with a PC.

Connect your PC and the Solar Inverter with the included Ethernet cable. X-patch cables can also be used.

The PC is connected to the master as standard. Basically all Solar Inverters – including Solar Inverters configured as secondary units or single units – dispose of an own web server so that a connection can be established with each device.

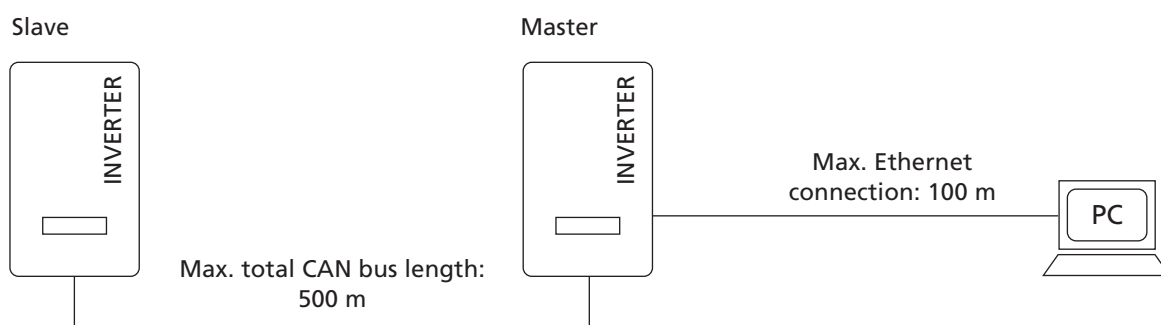

- To always find the suitable configuration for installation and commissioning on the PC, we recommend the use of a second network card (e.g. PCBus, PCMCIA), which you can configure to match the default setting of the Solar Inverter.
- The PC and the Solar Inverter must have suitable IP addresses and net masks. The network settings can be adjusted either directly on the Solar Inverter via the LCD display or on your PC.
- If two network cards are used the IP addresses must be in separate subnets, e.g. 192.168.30.XXX and 192.168.40.XXX.

6.4 Network settings on Solar Inverter



- The Solar Inverter is supplied with the following, preset IP address: **192.168.30.50**
- In the default setting the Solar Inverter does not support a DHCP (Dynamic Host Configuration Protocol). Therefore, the IP address is not assigned automatically. It is possible to activate the DHCP protocol via the Settings menu.
- IP addresses may only be assigned once within the network.

If required you can assign your own IP address for the Solar Inverter via the Settings menu.

1. Open the menu «Settings – Login».
2. Enter the default password (***** = 8 times star key) or your chosen password.



Please note:

Numerals from 0 – 9 and letters from a – z and from A – Z are admissible.

The password always has 8 characters. If the password you choose is fewer than 8 characters in length, the remainder, up to the full 8 characters, is filled with "*" symbols.

For example:

You choose "Solar" as your password. This password has 5 characters. The system therefore then automatically adds three "*" symbols, meaning that your password becomes "Solar***".

3. Open the menu «Settings – Network – Ethernet».

4. Enter an IP address suitable for use with your PC. This means the first three number blocks must be identical, and the last number block different.

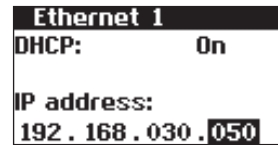

Example:

If your PC has the IP address 192.168.1.1, enter 192.168.1.2 for your Solar Inverter

5. Use to access further settings.

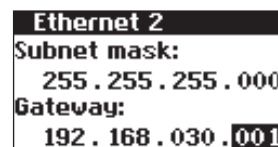

6. Enter the subnet mask 255.255.255.0.
7. Enter the IP address of your PC in the gateway.
8. Confirm with .

After the network configuration is completed you can start the Sunways Browser by entering the IP address of the Solar Inverter in the address line of your web browser.

6.5 Network settings on the PC

To enable your PC to communicate with the Solar Inverter certain network settings are required. The procedure differs slightly depending on the operating system. A configuration example for Windows® XP is shown below..



IP addresses may only be assigned once within the network.

1. Select «Start – Settings».
2. Select «Network Connections».
3. Double-click on the LAN connection through which you are connected to the Solar Inverter.

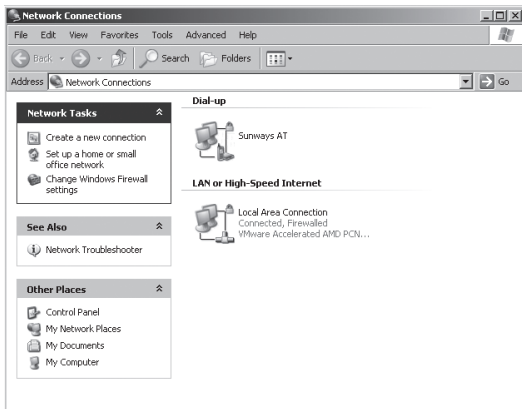

4. Click in the Status window on «Properties».

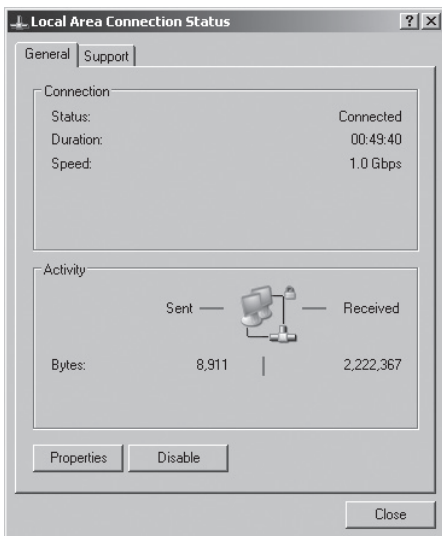

5. Select «Internet Protocol (TCP/IP)» and click «Properties» again.

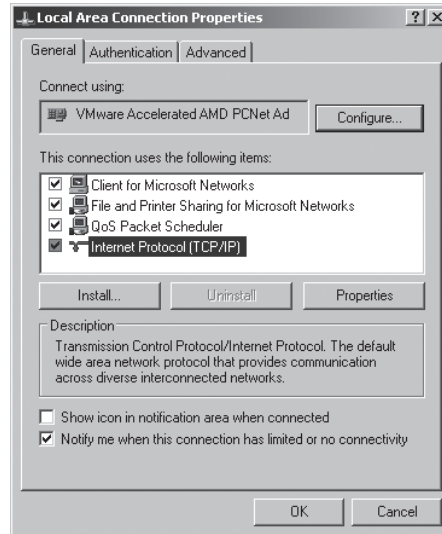

6. Now assign an unused IP address **192.168.30.XXX** and enter the subnet mask **255.255.255.0**.

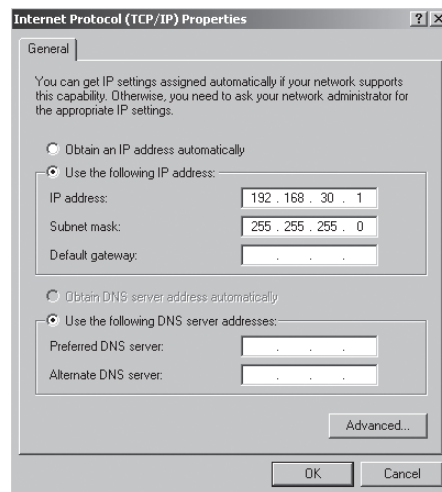

7. Click OK to confirm your entries.

8. In the «Status» menu item you can check the correctness of your entries and the status of your connection

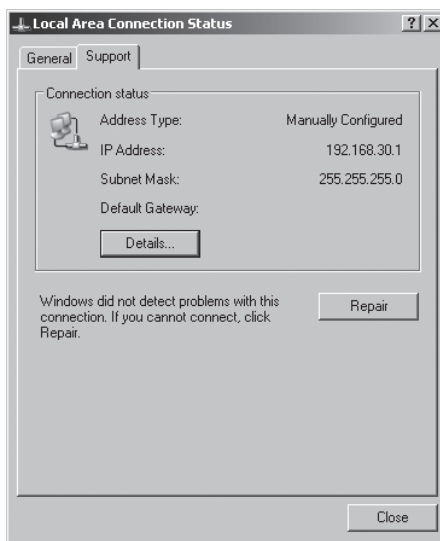

After the network configuration is completed you can start the Sunways Browser by entering the IP address of the Solar Inverter in the address line of your web browser.

For more complex network configurations please contact your network administrator.

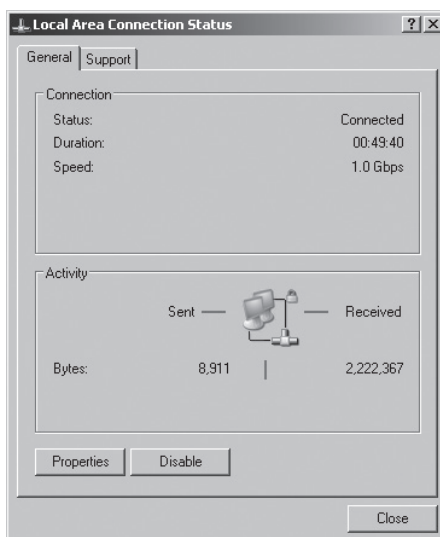

6.6 Connection via an existing Ethernet network

If an existing home or company network is available you can integrate the AT Solar Inverter directly in the network as a network device.

Connect your PC and the Solar Inverter with a CAT5 Ethernet cable with 1:1 RJ45 sockets.

The master is connected to the network as standard.

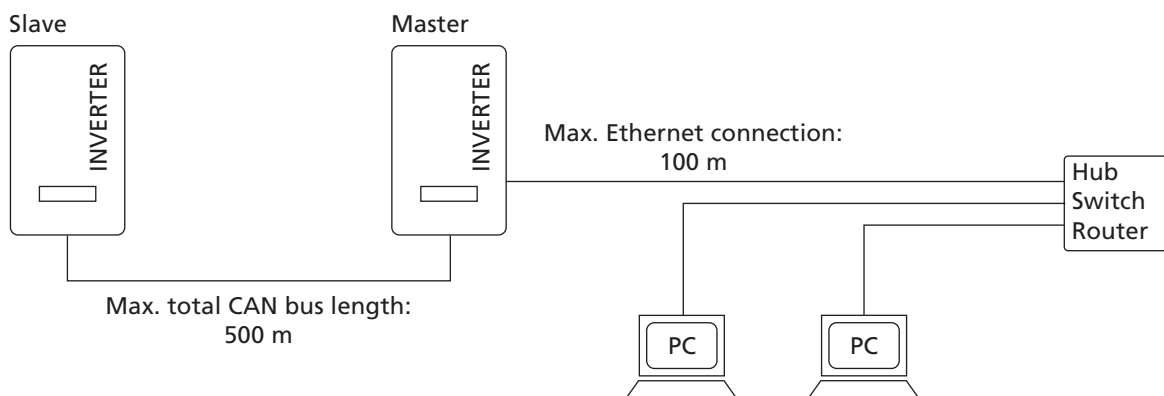

With DHCP

If a DHCP server is present in your network, you can activate DHCP on the Solar Inverter. In this case the Solar Inverter obtains the network settings automatically. You can display the assigned IP address via the LCD display (menu «Settings – Network – Ethernet»)

Without DHCP

If there is no DHCP server in your network, you must set an unused IP address on the AT Solar Inverter (see 6.4 Network settings on Solar Inverter on page 57).

Ask your network administrator for suitable settings for IP address, net mask and gateway.

After the network configuration is completed you can start the Sunways Browser by entering the IP address of the Solar Inverter in the address line of your web browser.

6.7 Access via DSL router

If a DSL connection or a network with Internet access is available you can make the Solar Inverter accessible via the Internet.

Requirement:

Your DSL modem or Internet router supports static IP address services, e.g. www.dyndns.org

Your router supports port forwarding.

1. Connect your Solar Inverter with your DSL router. Use a CAT5 Ethernet cable with 1:1 RJ45 sockets. The master is connected to the network as standard.
2. Register free of charge at www.dyndns.org, for example
3. Create an alias for accessing your Solar Inverter, e.g. at-sunways.dyndns.org. You can then access your Solar Inverter via this address.
4. Configure your DSL router such that the IP address is regularly reported to www.dyndns.org (follow the procedure described in the manual for your DSL router for this purpose).
5. Configure your DSL router such that it accepts requests from the Internet via Port 80, for example, and forwards them internally to the Solar Inverter (port forwarding).
6. Also note that the port for access from the Internet set in your firewall must be enabled.



Instructions for configuring common DSL routers are available for download from the Sunways AG website.

6.8 Connection via the Sunways Modem

A modem connection can be used to bridge longer distances during system monitoring and configuration. Connect the Sunways Modem with the Solar Inverter. The Sunways Modem is available as an analog, ISDN and GSM type.

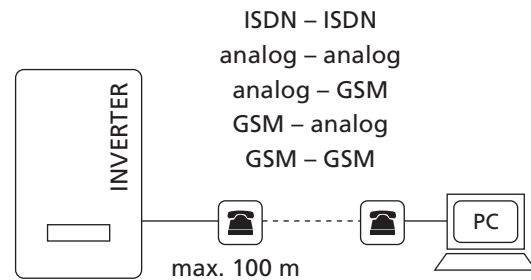

1. Connect your the Solar Inverter and your PC with a crossed or 1:1 Ethernet connection cable, type CAT5 with RJ45 sockets.



In a networked system only the master should be connected to the remote modem as standard.

2. Connect an external modem to your PC or, if available, use the internal modem of the PC. For commissioning please refer to the Sunways Modem user manual.



The following modem combinations are permitted:

ISDN – ISDN
analog – analog
analog – GSM
GSM – analog
GSM – GSM

Connecting a Sunways Modem

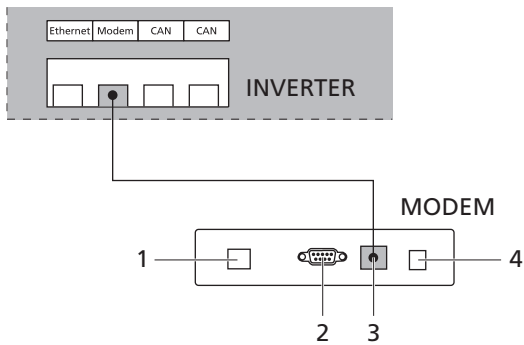

- 1 Telephone connection
- 2 RS232 interface
- 3 LVDS for AT and PT Solar Inverters
- 4 Power supply device

6.9 Dial-up connection from a PC to the Solar Inverter

To establish a connection between your Solar Inverter and a PC via the modem you have to establish a dial-up connection in Windows. The procedure under Windows® XP is described below.

1. Run the wizard for a new connection via Start – Settings – Network Connections.

Click «Next» to open the first selection screen.

2. Select «Connect to the network at my workplace».

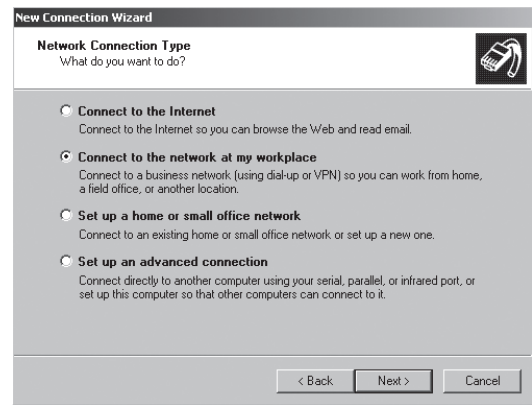

3. Confirm your selection with «Next» and select «Dial-up connection» on the next screen and confirm with «Next».



- A list of installed modems appears. Select the required modem and click «Next».

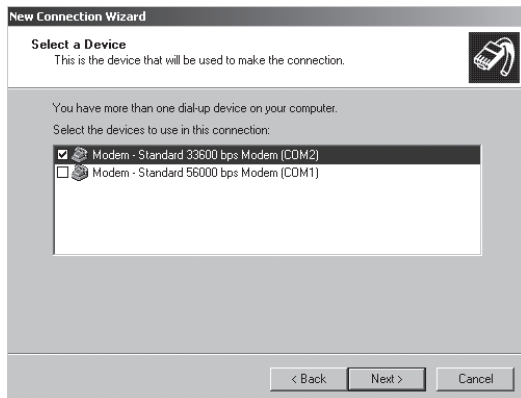

- Enter a connection name and click «Next».

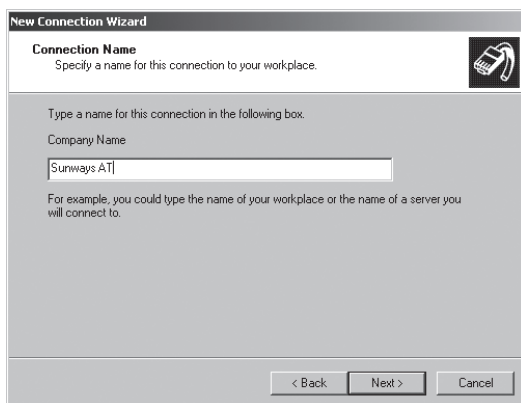

- Specify the phone number for your Sunways Solar Inverter.

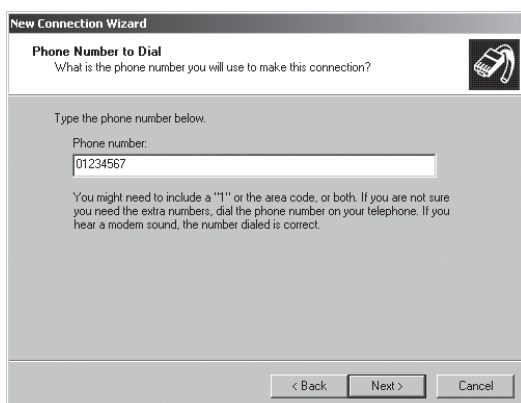

When entering the telephone number, you may have to include one or more digits to connect to an outside line. (An outside line is usually obtained by placing a «0» before the actual telephone number.)

Click «Next».

- Click the checkbox to place a shortcut on your desktop and click «Finish».



- The connection window appears automatically once the connection has been established. (Alternatively via the icon on your desktop or via «Start – Settings – Network Connections».)

Further settings are required in the «Properties» section.

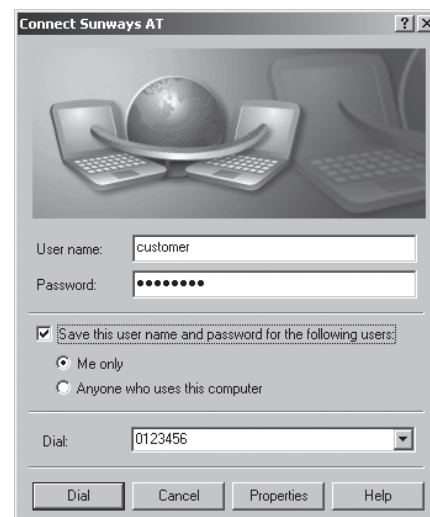

6 System monitoring

9. First click the «Networking» tab and select «Internet Protocol (TCP/IP)».

Select «Properties».

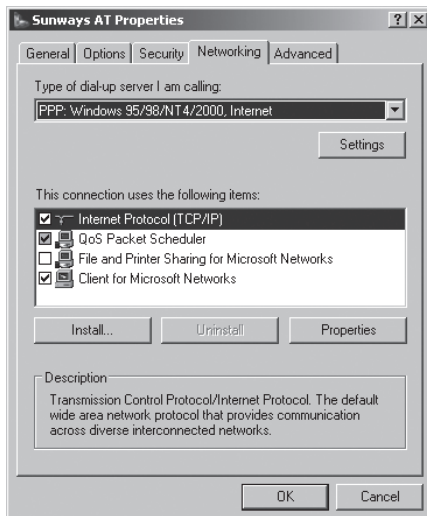

10. Enter the following data:

Obtain an IP address automatically
Obtain DNS server address automatically

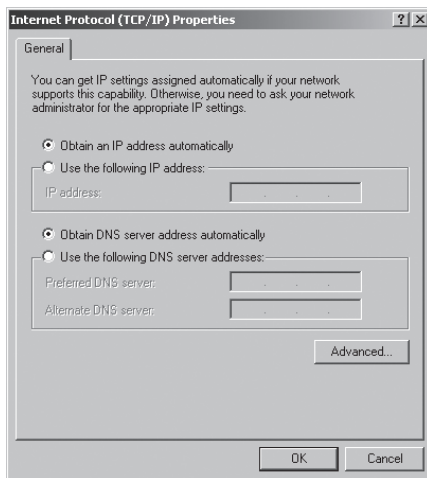

11. Enter «customer» as the user name and the standard password (***** = 8 times star key) or the password you entered previously.



The password matches the customer password on the device.

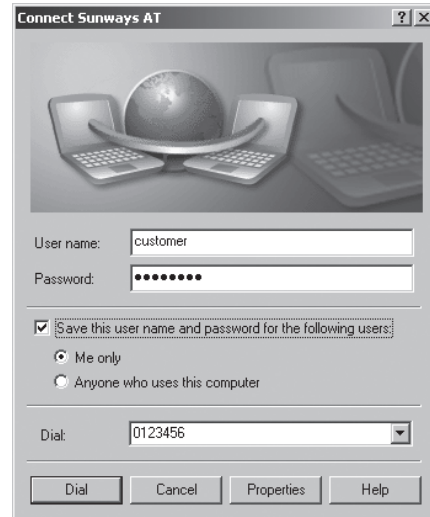

12. Click «Dial» to establish the connection. After the connection is established you can start the Sunways Browser by entering the IP address of the Solar Inverter in the address line of your web browser.



In contrast to the normal IP address for a modem connection the IP address of the Solar Inverter is set to **192.168.20.50** by default.

6.10 Sunways Browser

General information

The Sunways Browser can be called up via a standard Internet browser, e.g. Mozilla Firefox. One of the four possible connections between a PC and the Solar Inverter is required for this purpose:

- Direct connection via an Ethernet cable
- Connection via an existing internal Ethernet network
- Internet connection, e.g. connection of the Solar Inverter via DSL
- Connection via a Sunways Modem

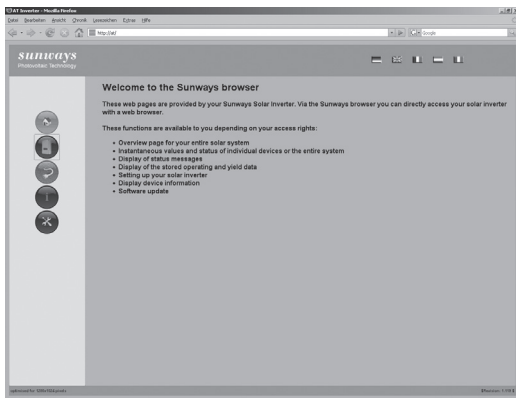

After entering the IP address for the Solar Inverter in the address line of the browser the following functions are available:

- Display of the operating mode and instantaneous values for a single device or for a CAN-networked system
- Display of energy yields as 5-minute, daily, monthly, annual and total values
- 5-minute mean values of solar generator current and voltage, grid current and voltage and feed-in power
- Settings, e.g. for date/time, interface configuration, alerting options, communication parameters etc.

- Communication software update (LCD display, interfaces, communication and Sunways Browser) and the control software (control and monitoring)

Access protection

The Sunways Browser is provided with password protection so that unauthorised persons cannot access your Solar Inverter.

The following user data are set in the delivered state:



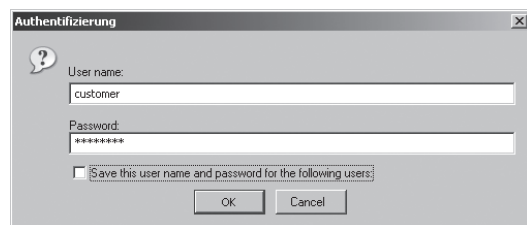

User: customer
Password: * * * * * *



- It is recommended that you change this password to an 8-digit/character password.
- This password is identical to the password entered via the LCD display for settings and commissioning.
- Numerals from 0 – 9 and letters from a – z and from A – Z are admissible.
- The password always has 8 characters. If the password you choose is fewer than 8 characters in length, the remainder, up to the full 8 characters, is filled with "*" symbols.
- For example:
 You choose "Solar" as your password. This password has 5 characters. The system therefore then automatically adds three "*" symbols, meaning that your password becomes "Solar***".

- If you cannot remember the password you can request a device-specific password from the Technical Hotline so that you can access your Solar Inverter again. In this case you should be able to present proof of purchase of the Solar Inverter.

Overview – Menu

-  Home – Displays the start page
-  Solar Inverter – Displays the instantaneous values, stored operating data, Solar Inverter status
-  Solar System – Displays a system overview with status, total output, yields and access to slaves (only available if the device is connected with the master).
-  Information – Device information, e.g. serial number
-  Settings and software update for the device or the networked system

Language selection

The web pages are available in German, English, French, Spanish and Italian. Click on the respective country flag to select the language.

Setting the date/time

This function can be accessed via Settings – Date/Time. If you have selected the correct time zone and an Internet connection is available, you can automatically synchronise the time of the Solar Inverter with a time server with the NTP button.

Alternatively you can transfer the PC time to the Solar Inverter.

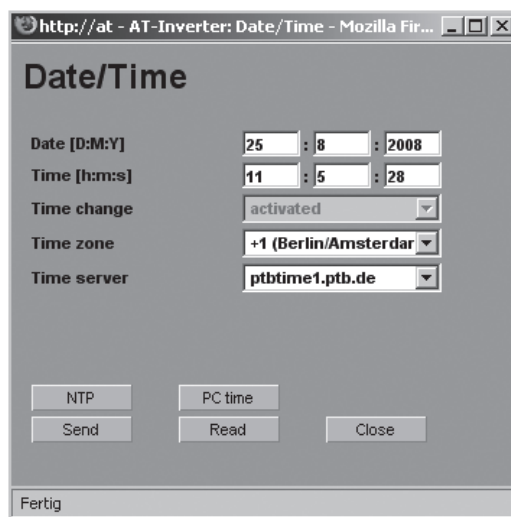

Please proceed with caution for time settings, as they directly affect data logging. For example, if you set the time back by 1 hour, then the existing data for the last hour will be overwritten.

Software update

The software update is used to extend the functionality of your Solar Inverter. The communication software (responsible for LCD display, interfaces, communication and Sunways Browser) and the control software or the monitoring software can be updated.

1. Select «Settings – Software Update». This function requires entry of a password (default: ***** = 8 times star key or the password you entered previously).
2. The upper screen section shows the current software versions. If a new version is available on our website (www.sunways.de), you can download the file and load it via the Sunways Browser. Select the file on your hard disk via the «Browse...» button and confirm with OK.
3. Then select the software you want to update (communication software, control software or monitoring software)
4. Click Update to copy the software update to the Solar Inverter.
5. Click Reboot to reboot the device and load the new software.



Alternatively the system update may be distributed to the slaves via the software master. Please contact our Technical Hotline for further information. The phone number is provided on the back of the manual.

6.11 Internet dial-up via modem

Modem settings

If you use a modem to connect to the Internet, the modem must be set up via the Sunways Browser. First establish a connection between your PC and the Solar Inverter (see section Direct Ethernet connection). Enter the following settings via «Settings – Modem» in your web browser:



Modem type

Select the modem type:
analog, ISDN or GSM

Internet dial-in number

Dial-in number for your Internet provider (ISP)

Outside line

If you have a telephone system, you may have to enter 0, for example. A comma results in a dialling pause of 1 second

Provider login

User name defined by your Internet provider

Provider password

Password defined by your Internet provider

PPP-IP

You can reach the Solar Inverter by entering this IP address in your web browser. The address is set to 192.168.20.50 by default.

MSN

MSN for the modem extension (ISDN modem). This is usually the extension number of without the area code.

SIM card PIN

SIM card PIN for GSM modem.

Function buttons

Click «Send» to save the settings in the Solar Inverter.

Click «Read» to display the current Solar Inverter settings.

Click «Modem Test» to test the connection between the modem and the ISP. You receive a reply as to whether dialling in was successful.



- Before conducting the modem test, the settings must be stored in the Solar Inverter by clicking «Send».
- Cheap ISP dial-up numbers are available from www.teltarif.de/internet or www.billiger-surfen.de, for example. Here you will find not only tariff information, but also the access data (phone number, user name, password).

E-mail settings

To enable the Solar Inverter to send E-mails, the E-mail settings must be stored via the Sunways Browser. The settings can be accessed via «Settings – Network» in the «Email Settings» section.



Requirements:

- When dialling in via modem, the correct dial-up settings must be stored (see Internet dial-up via modem).

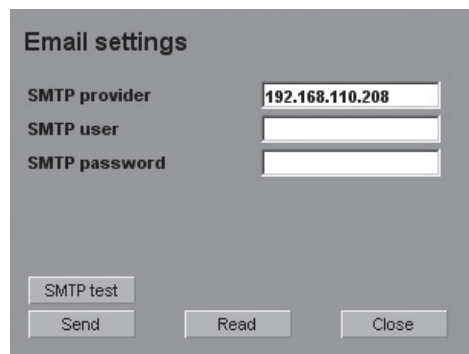

SMTP provider

SMTP server for sending e-mails, e.g. mail.gmx.net (max. 30 characters). Alternatively an IP address can be entered.

SMTP user

User name for your e-mail provider (generally your e-mail address), e.g. sunways@gmx.de (max. 50 characters)

SMTP password

Password for your e-mail provider

Function buttons

Via «SMTP Test» you can send a test e-mail to the e-mail address stored for active alerting.



- Before conducting the SMTP test, the settings must be stored in the Solar Inverter with «Send».
- During the SMTP test an e-mail is sent to the e-mail address stored in the monitoring system (active alerting). Before starting the test check whether a valid e-mail address is stored under active alerting.
- If the configured SMTP server does not use a login, the user and password fields must be left blank.

Click «Send» to save the settings in the Solar Inverter.

Click «Read» to display the current Solar Inverter settings.

6.12 Active alerting

General information

With active alerting you can receive status messages (errors and warnings) for your solar system by e-mail. If a status message was active for longer than 15 minutes or occurred 5 times in one day, you will receive an e-mail at the next full hour under the e-mail address stored in the Solar Inverter.



The master sends the status messages of all Solar Inverters if they are CAN-networked.

Requirements:

- The master must be connected to the Internet via a network or modem.
- When dialling in via modem, the correct dial-up settings must be stored (see Internet dial-up via modem).
- Correct e-mail settings must be stored in the Sunways Browser (see «Email settings»).

Alerting settings

The alerting settings can be accessed with the button «Settings – System Monitoring» in the «Active Alerting» section».

Active Email alerting

Activation or deactivation of the active alerting function.

Email address

In the «Email address» field enter the e-mail address to which messages should be sent.

Function buttons

Click «Send» to save the settings in the Solar Inverter.

Click «Read» to display the current Solar Inverter settings.

6.13 Sunways Portal connection

General information

The operating data of your solar system can be transferred to the Sunways Portal for remote monitoring via the Internet. This is possible without using a Sunways Communicator.

The portal connection is configured via the Sunways Browser. Following activation the master automatically sends a registration e-mail containing the system data (e.g. number of devices, serial number, etc.) to the Sunways Portal.

After activation the operating data are e-mailed to the Sunways Portal on a daily basis before the master is switched off for the night. Alternatively a shorter interval can be selected. If a change is made to your solar system (e.g. additional device), then the change is automatically reported to the Sunways Portal.

A basis access for the Sunways Portal for displaying the yield data is available to every Sunways customer free of charge. Expanded functions, e.g. the setpoint-actual comparison in the Sunways Portal, can also be purchased for a fee.



The master sends the status messages of all Solar Inverters if they are CAN-networked.

Requirements:

- The master must be connected to the Internet via a network or modem.
- Correct Email settings must be stored in the Sunways Browser (see «Email settings»)
- Correct portal settings must be stored in the Sunways Browser.

Setup

Check whether all requirements are met. Configure the specified settings if necessary.

Open the settings page in the Sunways Browser. This can be accessed under «Settings – System Monitoring» in the «Sunways Portal» section.

Portal connection

Activation or deactivation of the portal connection.

Portal address

Preset for the Sunways Portal

Mailbox file

Preset for the Sunways Portal

System ID

System ID assigned by the portal. This is generated automatically after portal activation and sent to the Solar Inverter. It can take up to 4 minutes before the Solar Inverter displays the system ID.

Portal Email

Preset for the Sunways Portal. Alternatively you can enter a different address if you wish to analyse the operating data yourself.

Email interval

Select the e-mail interval. If you operate the system on a DSL modem, you can set a short interval. If you use a modem connection, select a longer interval (e.g. daily) to avoid excessive telephone charges.

User Email

Enter an e-mail address for the confirmation e-mail sent by the portal. It contains a link for activating your system in the Sunways Portal.

User SMS

As an option you can specify an SMS number to which an SMS message is sent after your system is successfully set up in the portal.

Function buttons

With «Portal Test» you can test the portal connection. You receive an e-mail at the address specified under «User e-mail» and an SMS if you have entered your mobile phone number under «User SMS».



Before the portal test you must transmit the settings to your Solar Inverter via «Send». If the test was successful, a message is sent to the user e-mail address or the user SMS address.

Click «Send» to save the settings in the Solar Inverter.

To view your system data in the Sunways Portal, you require a user account. This will be issued to you if you follow the link in the confirmation e-mail and fill out the registration form.

Alternatively you can enter an existing user name with the correct password to assign the system to an existing user account.

7 Appendix

7.1 Technical data

Model	AT 2700	AT 3000	AT 3600	AT 4500	AT 5000
Article no.	SI227AT0B	SI230AT0B	SI250AT0B	SI245AT0B	SI250AT0B
DC Input					
Rated DC power	2850 W	3150 W	3800 W	4750 W	5250 W
Maximum DC current	15,5 A	15,5 A	15,5 A	22,0 A	22,0 A
Nominal DC voltage	350 V				
MPP voltage range	181 V...600 V	203 V...600 V	242 V...600 V	214 V...600 V	236 V...600 V
Maximum voltage DC	680 V				
Number of inputs per MPP tracker	2 x Tyco Solarlok				
Number of MPP trackers	1				
AC output					
Rated AC output power	2700 W	3000 W	3600 W	4500 W	5000 W
Maximum AC power	2700 W	3000 W	3600 W	4500 W	5000 W
Nominal AC current	11,7 A	13,0 A	15,7 A	19,6 A	21,7 A
Maximum AC current	12,5 A	14,0 A	17,0 A	21,0 A	23,0 A
Nominal frequency	50 Hz				
Frequency tolerance range	47,5 Hz...50,2 Hz (according to DIN VDE 0126-1-1)				
Grid voltage	230 V				
AC voltage range	-20%...+15% (according to DIN VDE 0126-1-1)				
Distortion factor at Pn	< 4%				
Reactive power factor (cos phi)	ca. 1				
Grid voltage monitoring	single-phase (according to DIN VDE 0126-1-1)				
Earth fault protection	RCD (according to DIN VDE 0126-1-1)				
Insulation, frequency and DC current monitoring	integrated according to DIN VDE 0126-1-1				
Required phases, number of grid connections	1 (L, N, PE)				
Number of feed-in phases (230 V single-phase)	1				
Performance					
Stand-by consumption	6,5 W				
Night-time consumption	< 0,06 W				
Maximum efficiency	95,5%	95,5%	95,5%	95,5%	95,5%
European efficiency	94,7%	94,8%	94,9%	95,0%	95,0%
MPP efficiency (static)	> 99%	> 99%	> 99%	> 99%	> 99%
Switching concept	HERIC® / FP topology, transformerless				

Other

DC switch	internal, mechanical
Grid-connection fuse layout	16 A 16 A 25 A 25 A 32 A
Data interfaces	Ethernet, CAN, RS485, voltageless alarm relay, 50 pulse output, modem
Sensor interfaces	irradiation, temperature
Display	LCD, backlit, 128 x 64 pixels
Plant supervision	Active alarm via e-mail, Sunways Browser, Sunways Portal
IP degree of protection according to IEC 60529	IP 54
Max. relative humidity	95%
Cooling	free convection
Ambient temperature	-25°C...40°C (at full load)
Overload behaviour	working point adjustment
Dimensions (height x width x depth)	59 x 35 x 21 cm
weight	29 kg
Type of installation	wall installation
Noise development	< 35 dB (A)
Standard warranty (option)	5 years (10/15/20/25 years)
Certificates	CE, DIN VDE 0126-1-1

7.2 Drilling template for wall bracket

You can use the following template to install the wall bracket. All distances and measures are shown on this drawing.

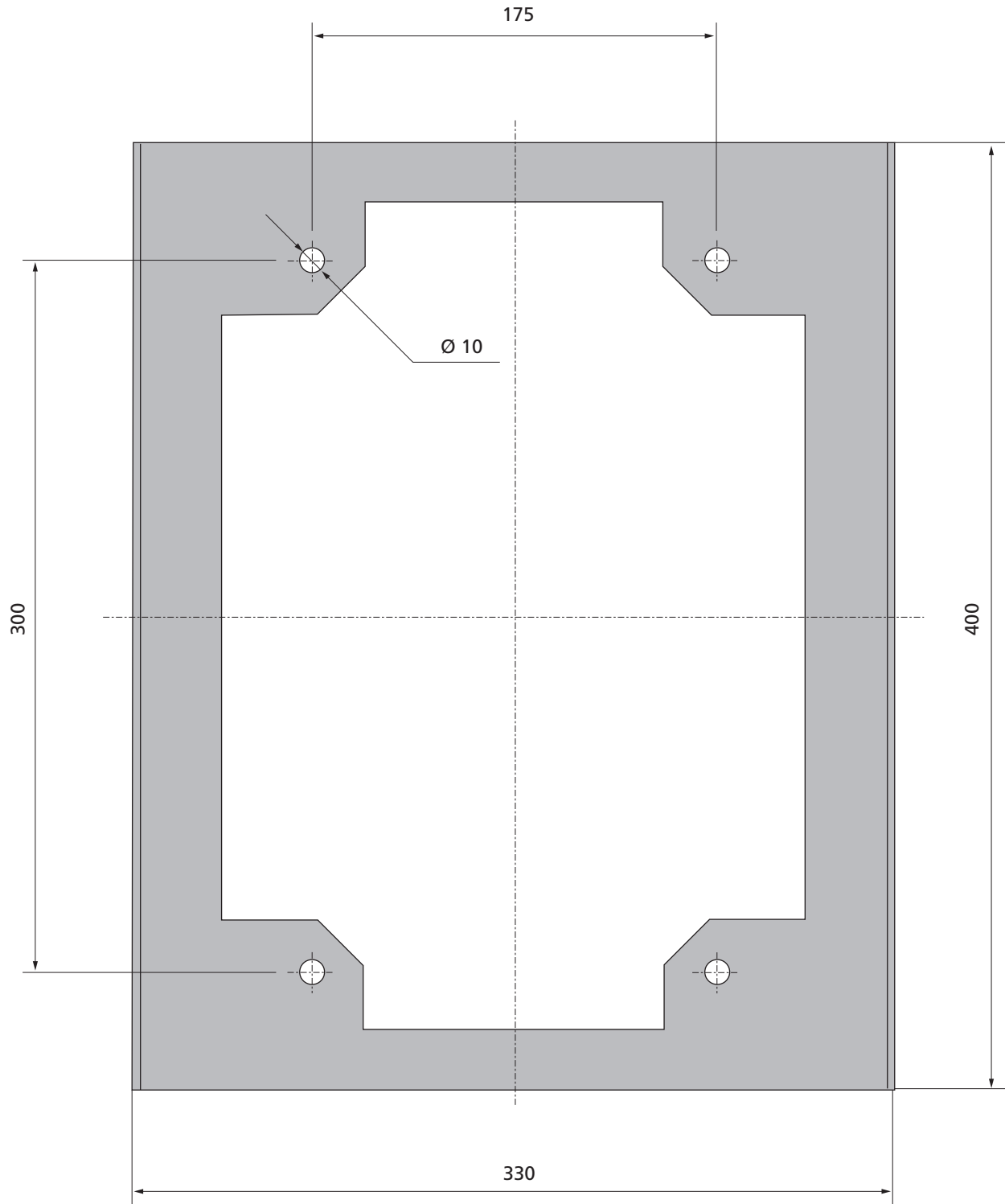

7.3 General liability disclaimer

Although information contained in this manual has been checked with the greatest care for its accuracy and completeness, not liability whatsoever can be accepted for errors or omissions.

- Sunways AG reserves the right to change the hardware and software features described here at any time without prior notice.
- This manual may only be reproduced, passed on, copied or translated into other languages in whole or in part in any form or with any means the prior written approval of Sunways AG.
- Sunways AG shall assume no guarantee for damage caused by faulty or lost data, due to incorrect operation or the malfunction of the Solar Inverter, the software, additional devices or PCs.

All rights reserved. © Sunways AG

The products named on the cover page are protected by copyright and sold under licence. No part of this document may be reproduced in any form without prior written approval of Sunways AG and the Sunways licensors.

Registered trademarks

The Sunways logo is a registered trademark of Sunways AG, Konstanz.

HERIC® is a registered trademark of Fraunhofer Gesellschaft, Munich.

Sunways AG
Photovoltaic Technology
Macairestraße 3 - 5
78467 Konstanz
Germany
Phone +49 (0)7531 996 77-0
Fax +49 (0)7531 996 77-444
email info@sunways.de
www.sunways.de

Technical Hotline

Germany: +49 (0)7531 996 77-577
Spain: +34 93 665 20-40

Sunways
Photovoltaic Technology